

GDM-F520

SERVICE MANUAL

AEP Model
US Model
Canadian Model
Chassis No. SCC-L33D-A

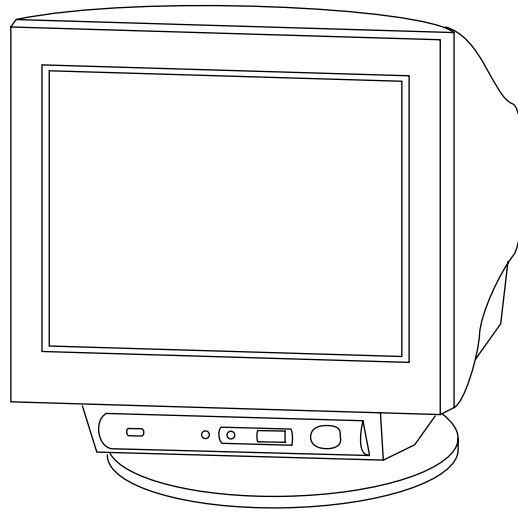

CR1 CHASSIS

SPECIFICATIONS

CRT	0.22 mm aperture grille pitch, 90-degree deflection, FD Trinitron 21 inches measured diagonally	AC input voltage/current	100 to 240 V, 50 – 60 Hz, 2.0 – 1.0 A
Viewable image size	Approx. 403.8 × 302.2 mm (w/h) (16 × 12 inches) 19.8" viewing image	Power Consumption (with no USB devices connected)	Approx. 145 W
Resolution (H:Horizontal, V:Vertical)	Maximum: H: 2048 dots, V: 1536 lines Recommended: H: 1600 dots, V: 1200 lines	Operating temperature	10 °C to 40 °C
Input signal levels	Video signal: Analog RGB: 0.700 Vp-p (positive), 75 Ω SYNC signal: H/V separate or composite sync: TTL 2 kΩ, Polarity free Sync on Green: 0.3 Vp-p (negative)	Dimensions	Approx. 497 × 499 × 487 mm (w/h/d) (19 ⁵ / ₈ × 19 ³ / ₄ × 19 ¹ / ₄ inches)
Standard image area	Approx. 388 × 291 mm (4:3) (15 ³ / ₈ × 11 ¹ / ₂ inches) or Approx. 364 × 291 mm (5:4) (14 ³ / ₈ × 11 ¹ / ₂ inches)	Mass	Approx. 30 kg (66 lb 2 oz)
Deflection frequency (H:Horizontal, V:Vertical)	H: 30 to 137 kHz, V: 48 to 170 Hz	Plug and Play	DDC2B/DDC2Bi
		Supplied accessories	Power cord HD15 video signal cable USB cable Exclusive Power Mac G3/G4 adapter This instruction manual

Design and specifications are subject to change without notice.

TORINITORON® COLOR GRAPHIC DISPLAY
SONY®

SAFETY CHECK-OUT

After correcting the original service problem, perform the following safety checks before releasing the set to the customer:

1. Check the area of your repair for unsoldered or poorly-soldered connections. Check the entire board surface for solder splashes and bridges.
2. Check the interboard wiring to ensure that no wires are “pinched” or contact high-wattage resistors.
3. Check that all control knobs, shields, covers, ground straps, and mounting hardware have been replaced. Be absolutely certain that you have replaced all the insulators.
4. Look for unauthorized replacement parts, particularly transistors, that were installed during a previous repair. Point them out to the customer and recommend their replacement.
5. Look for parts which, though functioning, show obvious signs of deterioration. Point them out to the customer and recommend their replacement.
6. Check the line cords for cracks and abrasion. Recommend the replacement of any such line cord to the customer.
7. Check the B+ and HV to see if they are specified values. Make sure your instruments are accurate; be suspicious of your HV meter if sets always have low HV.
8. Check the antenna terminals, metal trim, “metallized” knobs, screws, and all other exposed metal parts for AC Leakage. Check leakage as described right.

LEAKAGE TEST

The AC leakage from any exposed metal part to earth ground and from all exposed metal parts to any exposed metal part having a return to chassis, must not exceed 0.5 mA (500 microamperes).

Leakage current can be measured by any one of three methods.

1. A commercial leakage tester, such as the Simpson 229 or RCA WT-540A. Follow the manufacturers’ instructions to use these instruments.
2. A battery-operated AC milliammeter. The Data Precision 245 digital multimeter is suitable for this job.
3. Measuring the voltage drop across a resistor by means of a VOM or battery-operated AC voltmeter. The “limit” indication is 0.75 V, so analog meters must have an accurate low-voltage scale. The Simpson 250 and Sanwa SH-63Trd are examples of a passive VOMs that are suitable. Nearly all battery operated digital multimeters that have a 2 V AC range are suitable. (See Fig. A)

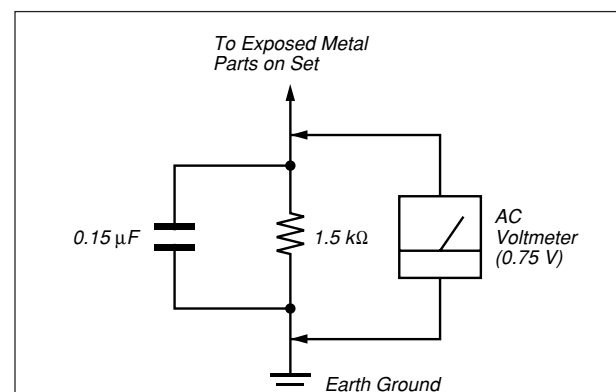

Fig. A. Using an AC voltmeter to check AC leakage.

WARNING!!

NEVER TURN ON THE POWER IN A CONDITION IN WHICH THE DEGAUSS COIL HAS BEEN REMOVED.

SAFETY-RELATED COMPONENT WARNING!!

COMPONENTS IDENTIFIED BY SHADING AND MARK \triangle ON THE SCHEMATIC DIAGRAMS, EXPLODED VIEWS AND IN THE PARTS LIST ARE CRITICAL FOR SAFE OPERATION. REPLACE THESE COMPONENTS WITH SONY PARTS WHOSE PART NUMBERS APPEAR AS SHOWN IN THIS MANUAL OR IN SUPPLEMENTS PUBLISHED BY SONY. CIRCUIT ADJUSTMENTS THAT ARE CRITICAL FOR SAFE OPERATION ARE IDENTIFIED IN THIS MANUAL. FOLLOW THESE PROCEDURES WHENEVER CRITICAL COMPONENTS ARE REPLACED OR IMPROPER OPERATION IS SUSPECTED.

AVERTISSEMENT!!

NE JAMAIS METTRE SOUS TENSION QUAND LA BOBINE DE DEMAGNETISATION EST ENLEVÉE.

ATTENTION AUX COMPOSANTS RELATIFS À LA SÉCURITÉ!! LES COMPOSANTS IDENTIFIÉS PAR UNE TRAME ET UNE MARQUE \triangle SONT CRITIQUES POUR LA SÉCURITÉ. NE LES REMPLACER QUE PAR UNE PIÈCE PORTANT LE NUMÉRO SPECIFIÉ. LES RÉGLAGES DE CIRCUIT DONT L'IMPORTANCE EST CRITIQUE POUR LA SÉCURITÉ DU FONCTIONNEMENT SONT IDENTIFIÉS DANS LE PRÉSENT MANUEL. SUIVRE CES PROCÉDURES LORS DE CHAQUE REMPLACEMENT DE COMPOSANTS CRITIQUES, OU LORSQU'UN MAUVAIS FONCTIONNEMENT EST SUSPECTÉ.

Note: Hand degauss must be used on stand-by or power-off condition.

This model has an automatic earth magnetism correction function by using an earth magnetism sensor and a LCC coil. When using a hand degauss while monitor (LCC coil) is being operated, it sometimes gets magnetized, and the system may not work properly as a result.

POWER SAVING FUNCTION

This monitor meets the power-saving guidelines set by VESA, TCO'99, and ENERGY STAR. If no signal is input to the monitor from your computer, the monitor will automatically reduce power consumption as shown below.

Power mode	Power consumption*¹	① (power) indicator
normal operation	≤ 145 W	green
active off* ² (deep sleep)* ³	≤ 3 W	orange

*¹ Figures reflect power consumption when no USB compatible peripherals are connected to the monitor.

*² When your computer enters power saving mode, NO SIGNAL appears on the screen. After a few seconds, the monitor enters power saving mode.

*³ “Deep sleep” is power saving mode defined by the Environmental Protection Agency.

DIAGNOSIS

Failre	Power LED
+B failure	Amber (0.5 sec) → Off (0.5 sec)
Horizontal / Vertical Deflection failure, Thermal protector	Amber (1.5 sec) → Off (0.5 sec)
ABL protector	Amber (0.5 sec) → Off (1.5 sec)
HV failure	Amber (0.25 sec) → Off (0.25 sec) → Amber (0.25 sec) → Off (1.25 sec)
Aging / Self Test	Amber (0.5 sec) → Off (0.5 sec) → Green (0.5 sec) → Off (0.5 sec)
Out of scan range	Green (OSD indication)

Aging Mode (Video Aging) : During Power Save, press MENU button for longer than 2 second.

Self Test (OSD Color Bar) : During Power Save, push up Control button for longer than 2 second.

Reliability Check Mode : During Power Save, push down Control button for longer than 2 second.

TIMING SPECIFICATION

MODE AT PRODUCTION	MODE 1	MODE 2	MODE 3	MODE 4
RESOLUTION	640 X 480	1600 X 1200	1920 X 1440	1920 X 1440
CLOCK	25.175 MHz	229.500 MHz	341.000 MHz	297.000 MHz
— HORIZONTAL —				
H-FREQ	31.469 kHz	106.250 kHz	128.485 kHz	112.500 kHz
	usec	usec	usec	usec
H. TOTAL	31.778	9.412	7.783	8.889
H. BLK	6.356	2.440	2.152	2.424
H. FP	0.636	0.279	0.457	0.485
H. SYNC	3.813	0.837	0.622	0.754
H. BP	1.907	1.325	1.073	1.185
H. ACTIV	25.422	6.972	5.630	6.465
— VERTICAL —				
V. FREQ (HZ)	59.940 Hz	85.000 Hz	84.977 Hz	75.000 Hz
	lines	lines	lines	lines
V. TOTAL	525	1250	1512	1500
V. BLK	45	50	72	60
V. FP	10	1	1	1
V. SYNC	2	3	3	3
V. BP	33	46	68	56
V. ACTIV	480	1200	1440	1440
— SYNC —				
INT(G)	NO	NO	NO	NO
EXT (H/V) /POLARITY	YES N/N	YES P/P	YES P/P	YES N/P
EXT (CS) /POLARITY	NO	NO	NO	NO
INT/NON INT	NON INT	NON INT	NON INT	NON INT

2000.8.9 VER.

TABLE OF CONTENTS

<u>Section</u>	<u>Title</u>	<u>Page</u>	<u>Section</u>	<u>Title</u>	<u>Page</u>
1. DISASSEMBLY			(1)	Schematic Diagram of A2 Board	4-8
1-1.	Cabinet Assembly Removal	1-1	(2)	Schematic Diagrams of D (Ⓐ, Ⓑ, Ⓒ) Board	4-10
1-2.	A2 Board (C Block) Removal	1-2	(3)	Schematic Diagram of DA Board	4-14
1-3.	A2 Board, US Board Removal	1-3	(4)	Schematic Diagram of H2 Board	4-16
1-4.	Bezel, H2 Board, Magnetic Sensor Removal	1-4	(5)	Schematic Diagram of L2 Board	4-18
1-5.	D Board Removal	1-5	(6)	Schematic Diagram of N Board	4-20
1-6.	Service Position	1-6	(7)	Schematic Diagram of US Board	4-22
1-7.	Picture Tube Removal.....	1-7	4-5.	Semiconductors	4-24
1-8.	Harness Location	1-9			
2. SAFETY RELATED ADJUSTMENT		2-1	5. EXPLODED VIEWS		5-1
3. ADJUSTMENTS		3-1	5-1.	Chassis	5-2
4. DIAGRAMS			5-2.	Picture Tube	5-3
4-1.	Block Diagrams	4-1	5-3.	Packing Materials	5-4
4-2.	Frame Schematic Diagram.....	4-4	6. ELECTRICAL PARTS LIST		6-1
4-3.	Circuit Boards Location	4-5			
4-4.	Schematic Diagrams and Printed Wiring Boards	4-6			

SECTION 1 DISASSEMBLY

1-1. CABINET ASSEMBLY REMOVAL

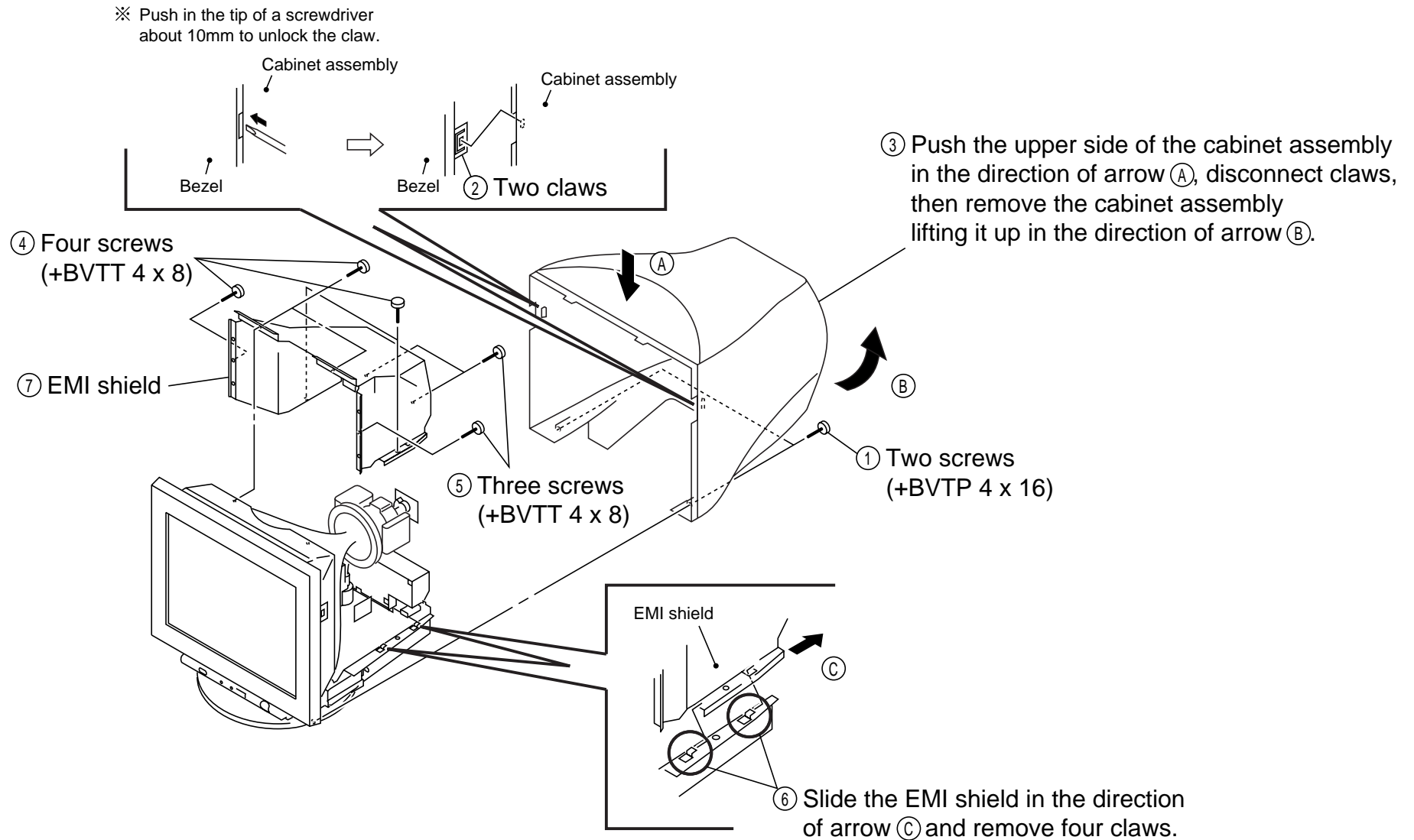

1-2. A2 BOARD (C BLOCK) REMOVAL

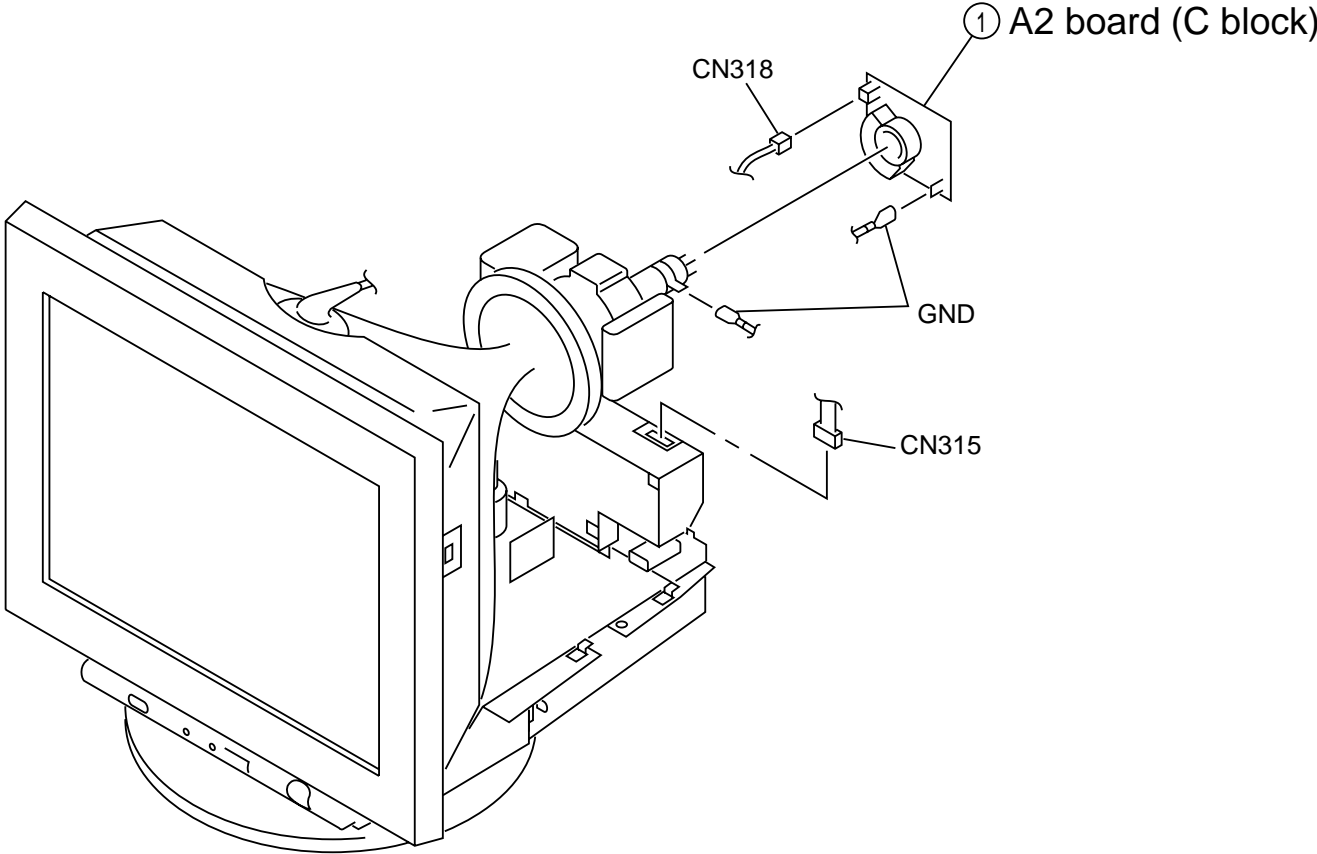

1-3. A2 BOARD, US BOARD REMOVAL

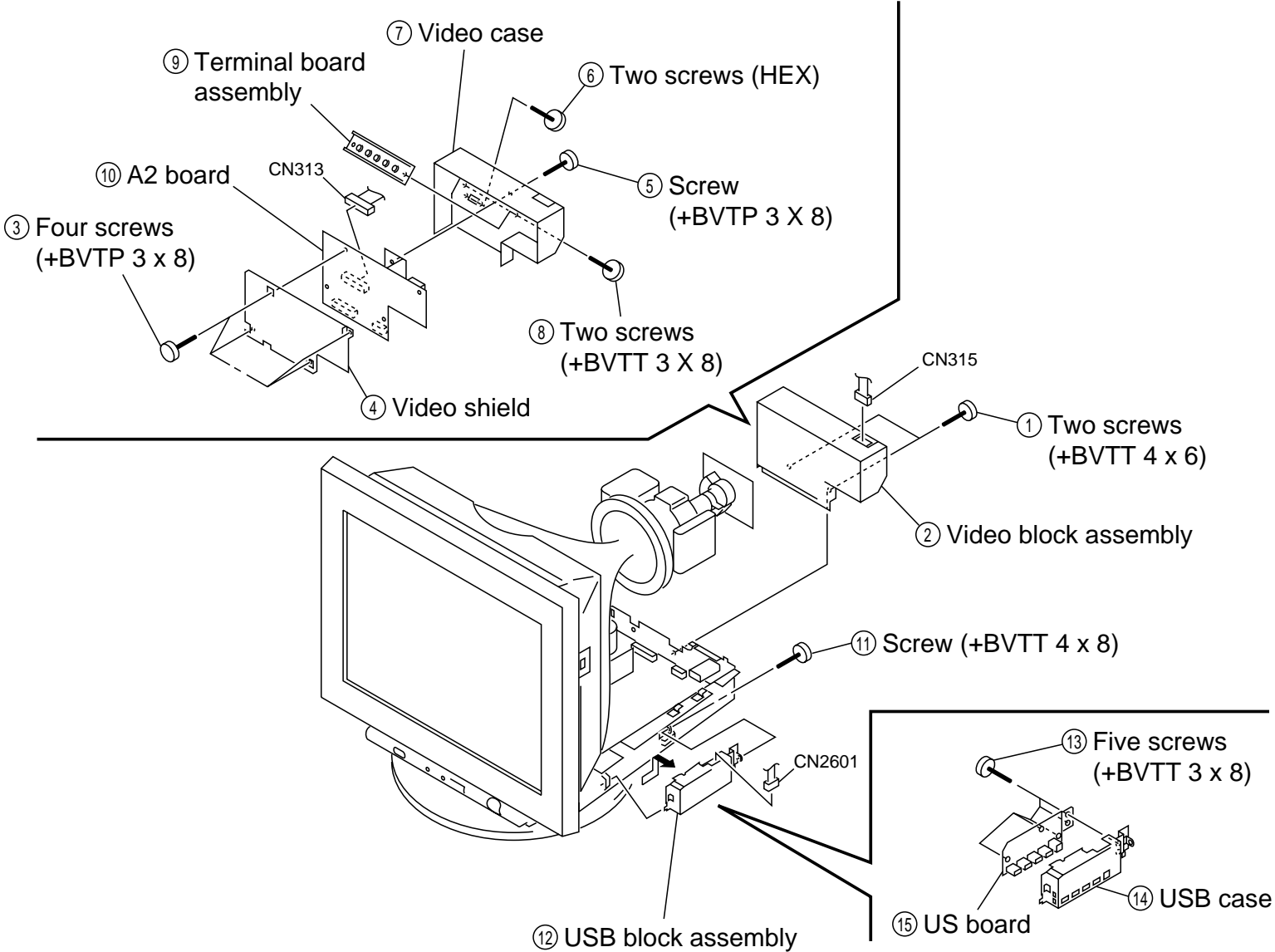

1-4. BEZEL, H2 BOARD, MAGNETIC SENSOR REMOVAL

- ① Before removing the bezel assembly, secure the picture tube by attaching two screws to the picture tube shield at the positions shown with an arrow (diagonal two places) to prevent the picture tube from falling.
(Use the screws +BVTT 4 x 8 that fix EMI shield.)

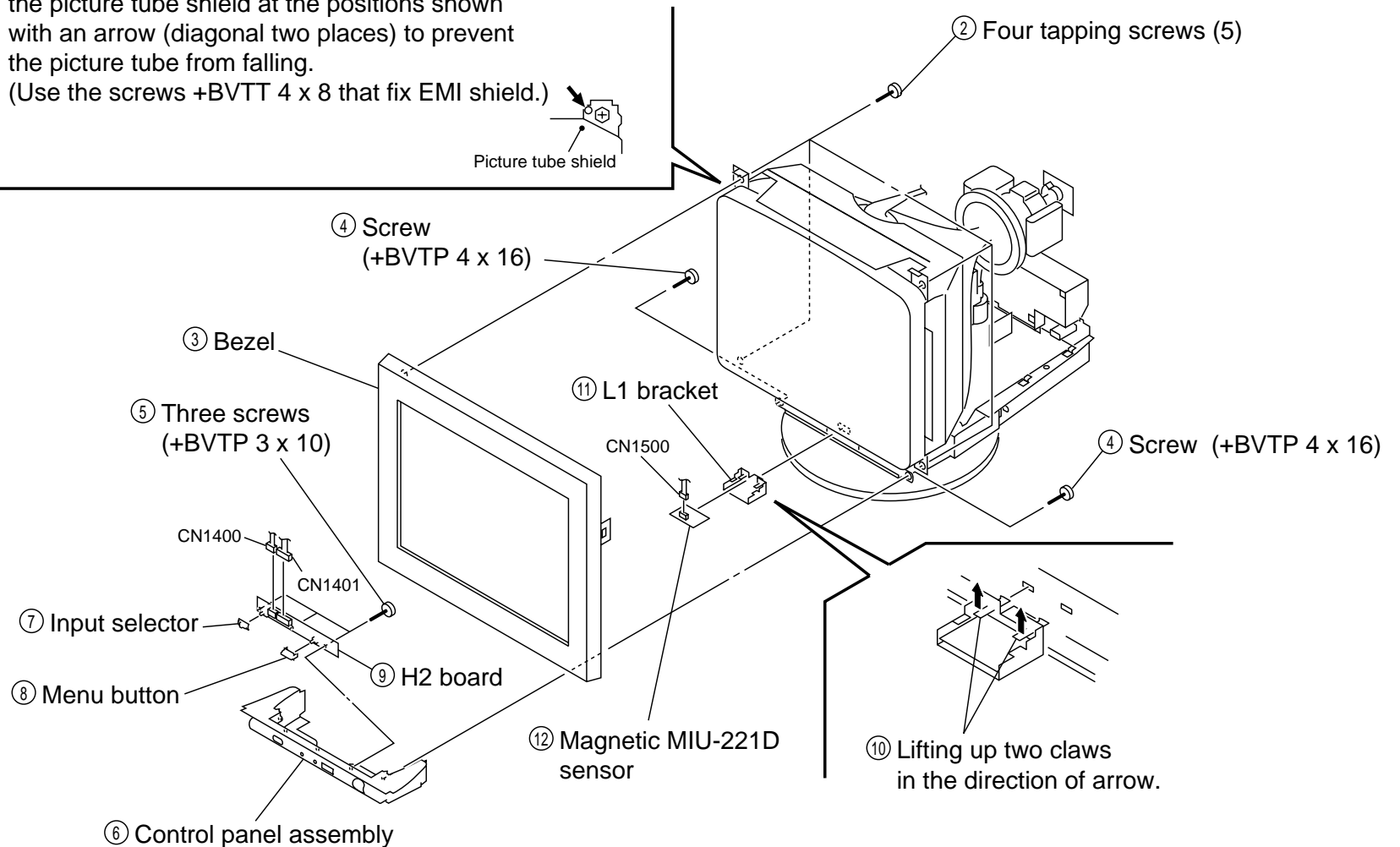

1-5. D BOARD REMOVAL

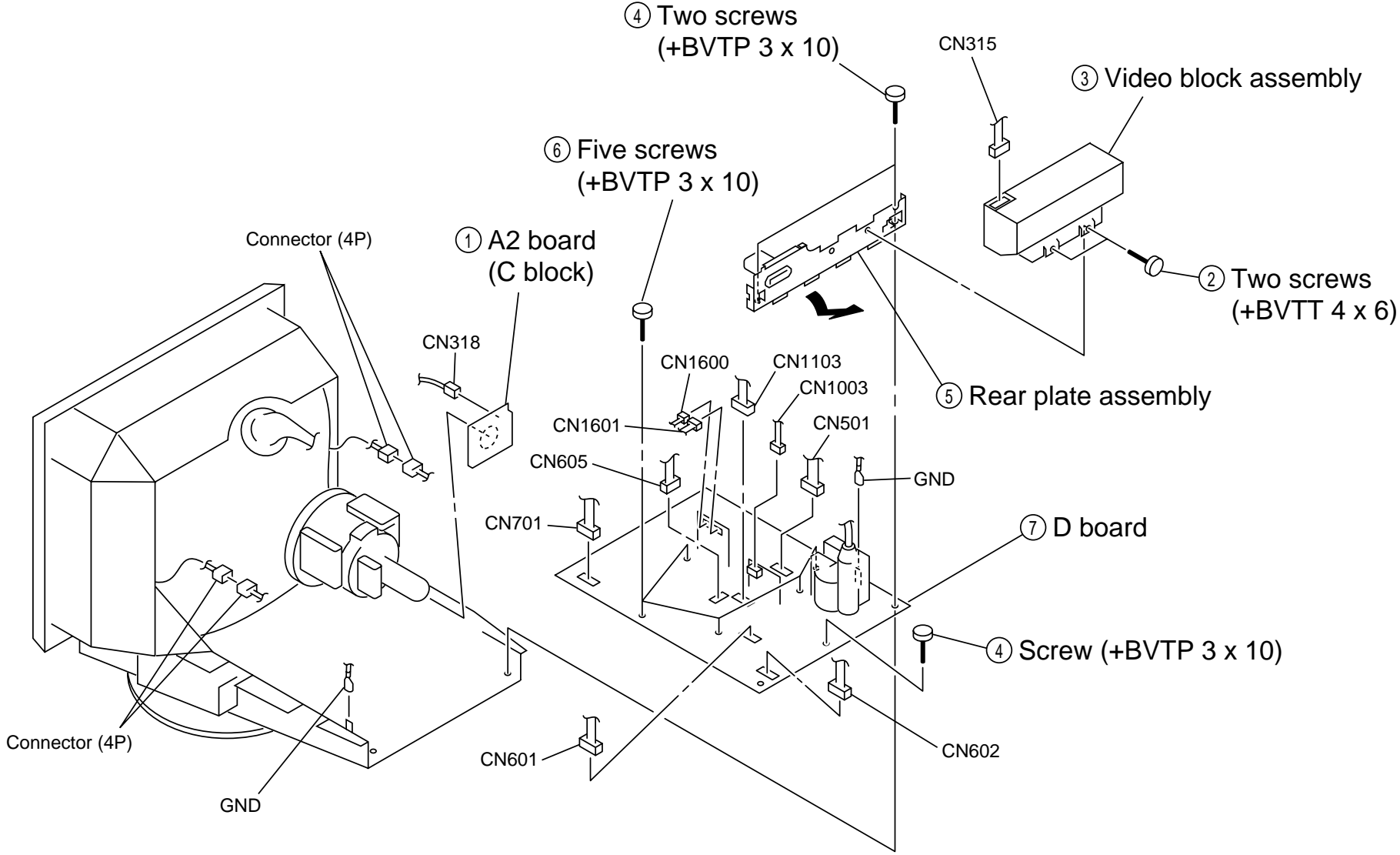

1-6. SERVICE POSITION

- ① Remove the D board.
- ② Remove the Video block assembly.
- ③ Install the Adaptor board (XT MOUNT) (A-1391-123-A).
- ④ Lay the Video block assembly.

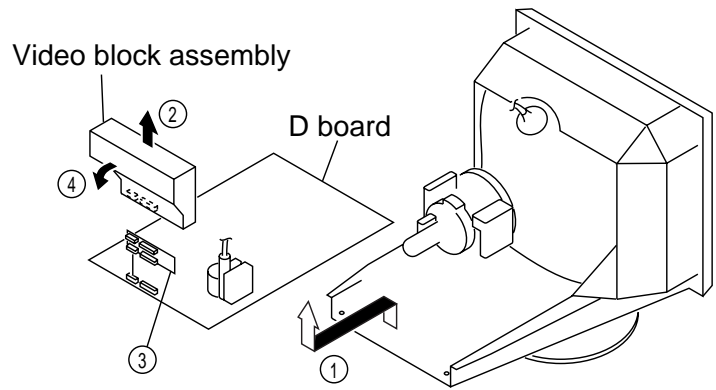

- ⑤ Install the video block assembly.

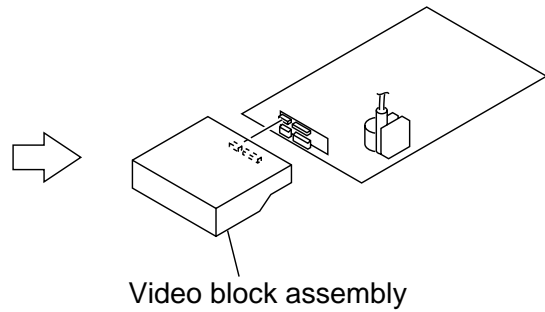

- ⑥ Put a box which is about 15cm in height under the D board to fix it.

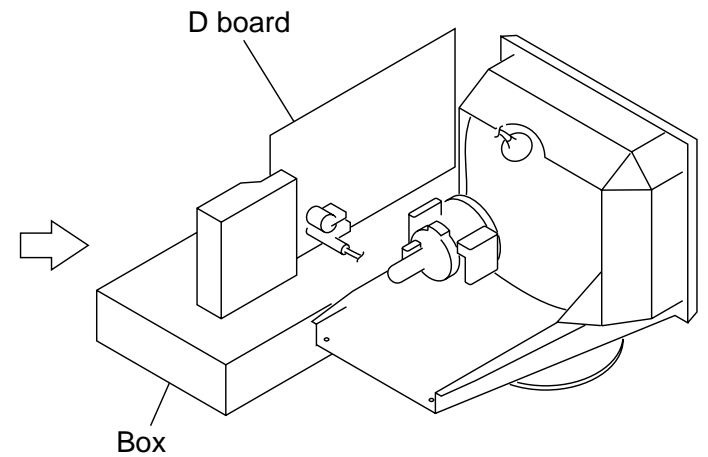

1-7. PICTURE TUBE REMOVAL

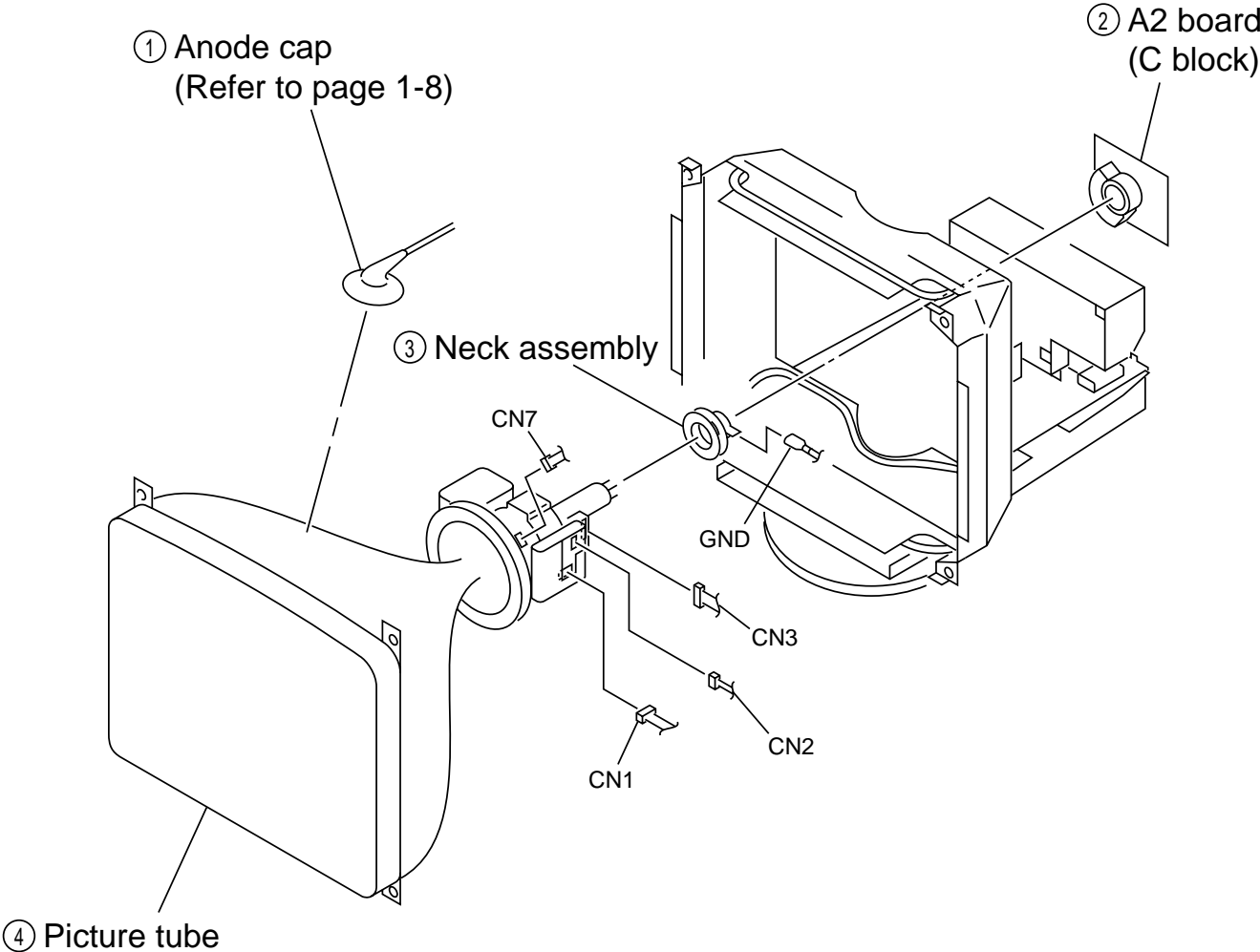

•REMOVAL OF ANODE-CAP

NOTE: Short circuit the anode of the picture tube and the anode cap to the metal chassis, CRT shield or carbon painted on the CRT, after removing the anode.

•REMOVING PROCEDURES

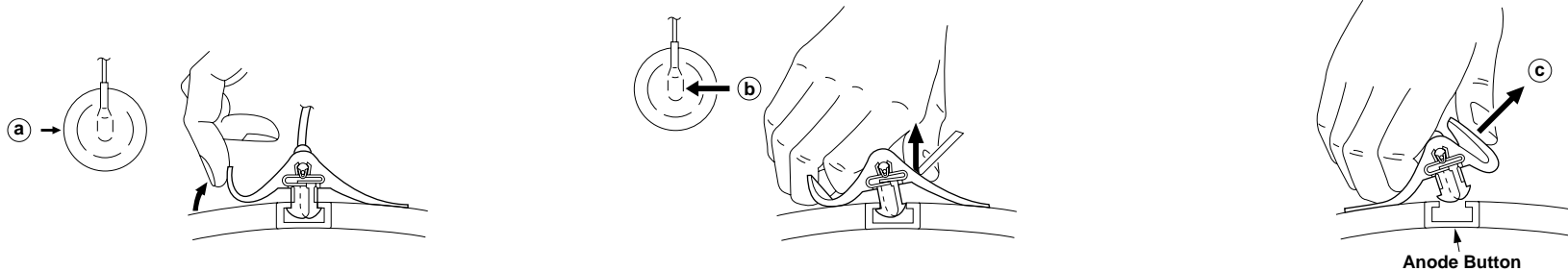

① Turn up one side of the rubber cap in the direction indicated by the arrow (a).

② Using a thumb pull up the rubber cap firmly in the direction indicated by the arrow (b).

③ When one side of the rubber cap is separated from the anode button, the anode-cap can be removed by turning up the rubber cap and pulling up it in the direction of the arrow (c).

•HOW TO HANDLE AN ANODE-CAP

① Don't scratch the surface of anode-caps with sharp shaped material!

② Don't press the rubber hardly not to damage inside of anode-caps!
A material fitting called as shatter-hook terminal is built in the rubber.

③ Don't turn the foot of rubber over hardly!
The shatter-hook terminal will stick out or damage the rubber.

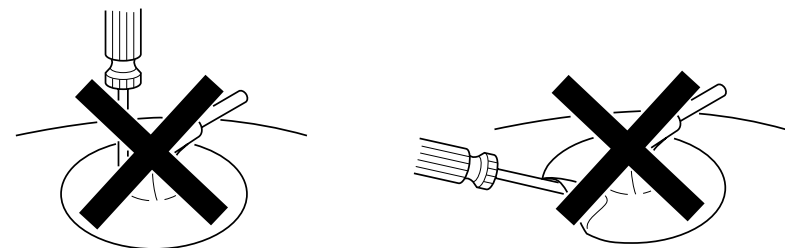

1-8. HARNESS LOCATION

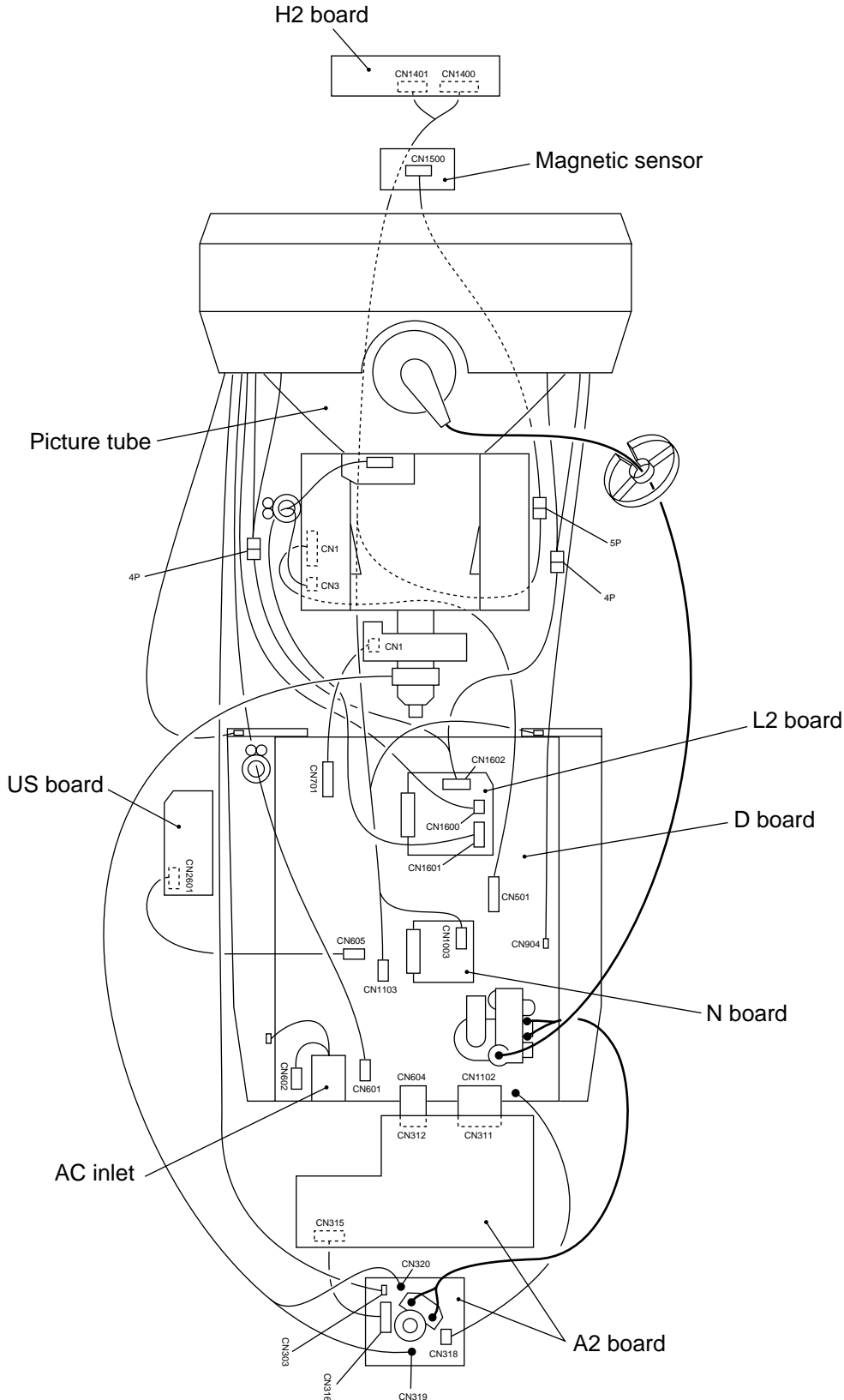

SECTION 2

SAFETY RELATED ADJUSTMENT

When replacing or repairing the shown below table, the following operational checks must be performed as a safety precaution against X-rays emissions from the unit.

	Part Replaced (☒)
HV ADJ	RV901

	Part Replaced (☑)
HV Regulator Circuit Check	D Board C925, IC901, R901, R902, R905, R924, R925, R926, RV901, T901 (FBT) • Mounted D Board
HV Protector Circuit Check	D Board C920, C923, D911, D912, R903, R917, R918, R919, R920, R923, T901 (FBT) • Mounted D Board N Board IC1001, RB1001 • Mounted N Board
Beam Current Protector Circuit Check	D Board C930, D917, R921, R932, R933, R935, T901 (FBT) • Mounted D Board N Board IC1001, RB1001 • Mounted N Board

* Confirm one minute after turning on the power.

a) HV Regulator Circuit Check

- 1) Turn the RV901 slowly, and adjustment so that high voltage is in the specified range.
[Specification]: 27.00 ± 0.05 kV
- 2) Check that the voltage of D912 cathode on the D board is 17.0 V or more.

b) HV Protector Circuit Check

- 1) Using external DC Power Supply, apply the voltage shown below between cathode of D912 and GND, and check that the RASTER disappears.
[Specification]: $19.95 + 0.00/- 0.05$ V

c) Beam Current Protector Circuit Check

- 1) Connect constant current source to a section between T901 (FBT) ⑪ pin and GND, and check that the RASTER disappears when the specified current flows to the ⑪ pin.
[Specification]: $2.12 + 0.00/- 0.01$ mA

SECTION 3 ADJUSTMENTS

Note: Hand degauss must be used on stand-by or power-off condition.

This model has an automatic earth magnetism correction function by using an earth magnetism sensor and a LCC coil. When using a hand degauss while monitor (LCC coil) is being operated, it sometimes gets magnetized, and the system may not work properly as a result.

• Landing Rough Adjustment

1. Display all white pattern (or black dot pattern).
2. Set contrast to 255.
3. Display green plain pattern.
4. Side back DY and roughly adjust green plain pattern to be centered on the useful screen with Purity Magnet.
5. Adjust DY tilt.

Note: Set ROTATION to 128 and LCC_NS to 128 when adjusting DY tilt.

6. Lightly tighten the DY screw.

• Landing Fine Adjustment

Note: (1) After adjust W/B (9300k), measure the average of IK with all white video input, while CONTRAST is maximum and BRIGHTNESS is center. And adjustment shall be made so that the miss-landing become least after aging 2H with the IK 30% of measured value shown above.

(2) The magnetic field shall be $BH = 0$.

(3) When adjusting at other than $BH = 0$, calculate the shifted value from $BH = 0$.

1. Put the monitor in helmholz coil.

2. Set as follows;

LCC_SW = 0 (LCC Correction Current = 0)

FUNCTION_SW bit1 = (Auto Degauss = On)

CONTRAST = 255

3. Display green plain pattern.
4. Degauss the iron part of chassis with a hand degausser and degauss coil.
5. Degauss CRT face with a hand degausser again.
6. Input AC 230V to AC IN and turn the monitor off and on. Then auto-degauss works.
7. Reset FUNCTION_SW bit1 to 0 (auto-degauss = off)
8. Degauss CRT face with a hand degausser again.
9. Attach wobbling coil to the specified place on CRT neck.
10. Put on landing sensor to CRT face.
11. Set LCC_SW to 12.
12. With landing checker, adjust DY position, purity, DY center and landing of the 4 corners.
13. Read VX and VY value which are the read out of magnetic sensor, and write to "LCC_VX_REF" and "LCC_VY_REF".

14. Adjust landing by LCC_NS, LCC_LT, LCC_LB, LCC_RT, and LCC_RB. Adjustment of registers shall be limited within the following range.

LCC_NS: 128 ± 15

LCC_LT, LCC_LB, LCC_RT, and LCC_RB: 128 ± 40

<Specifications>

Adjust so that the green is within the specification given right.

4 corner adjust target : within ± 1

_____ (μm)		
0 ± 3	0 ± 7.5	0 ± 3
0 ± 3	0 ± 7.5	0 ± 3
0 ± 3	0 ± 7.5	0 ± 3

The red and blue must be within the specification given right with respect to the green.

_____ (μm)		
± 6	± 6	± 6
± 6	± 6	± 6
± 6	± 6	± 6

A difference between red and blue must be within the specification given right.

_____ (μm)		
10	10	10
10	7	10
10	10	10

Set LCC_SW to 13, and Perform Service Save.

15. Tighten DY screw within specified torque, and auto-degauss.

Note: Torque 22 ± 2 kgcm ($2.2 \pm 0.2\text{Nm}$)

16. Adjust the vertical angle of DY to make top and bottom pins equal (a = b). The horizontal angle shall not be changed (straight). Settle DY upright without leaning, and insert wedges firmly so that DY shall not move.

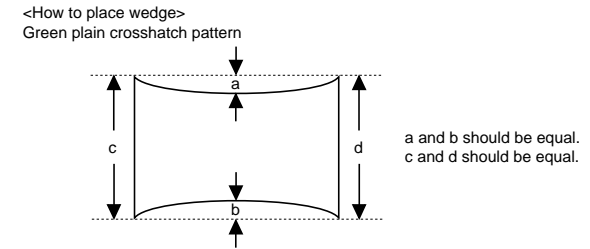

Plaster RTV to both sides for the upper wedge.
Make sure that they settle inside DY.

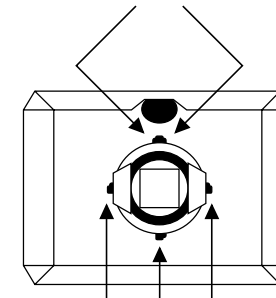

Plaster RTV to one side for other wedges.

17. Adjust top and bottom pins correction VR.

18. Adjust the horizontal trapezoid distortion by DY horizontal trapezoid correction VR.

19. Check landing at each corner and in case not in specification, adjust landing of 4 corners with "LCC_NS", "LCC_LT", "LCC_LB", "LCC_RT", and "LCC_RB". The limitations of registers are shown below.

LCC_NS: 128 ± 15

LCC_LT, LCC_LB, LCC_RT, and LCC_RB: 128 ± 40

20. Remove the sensor and wobbling coil.

21. Switch signals to R, G, and B, and then check that the pure colors have good color purity.

22. Fix purity magnets with white paint.

Connect the communication cable of the computer to the connector located on the D board. Run the service software and then follow the instruction.

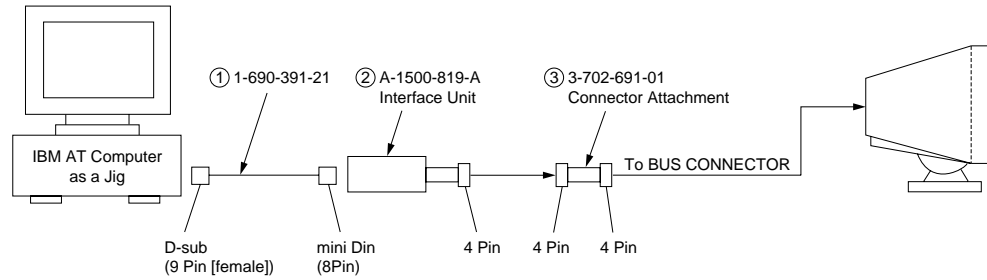

*The parts above (① ~ ③) are necessary for DAS adjustment.

• Convergence Rough Adjustment

- (1) Display white crosshatch pattern.
- (2) Pile the convex parts of 6-pole magnet for convergence together.
- (3) Roughly adjust H.CONV and V.CONV with 4-pole magnet.

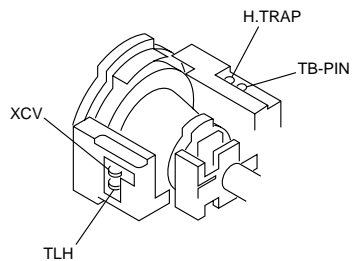
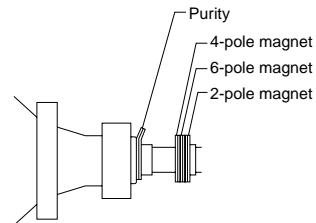

XCV

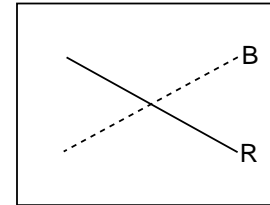

XBV

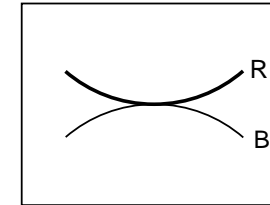

TLH

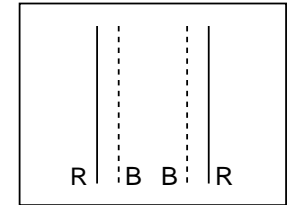

TLV

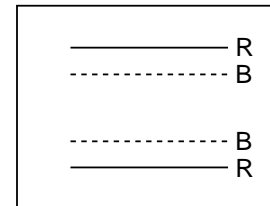

YCH

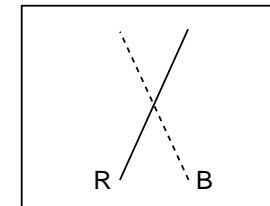

YBH

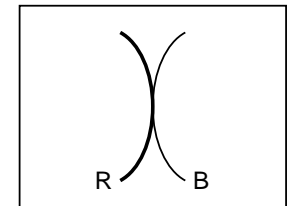

• Convergence Specification

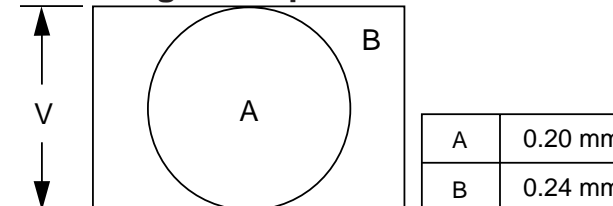

• **White Balance Adjustment Specification**

1. 9300 K
 $x = 0.283 \pm 0.005$
 $y = 0.298 \pm 0.005$
 (All White)
2. 6500 K
 $x = 0.313 \pm 0.005$
 $y = 0.329 \pm 0.005$
 (All White)
3. 5000 K
 $x = 0.346 \pm 0.005$
 $y = 0.359 \pm 0.005$
 (All White)

• **Vertical and Horizontal Position and Size Specification**

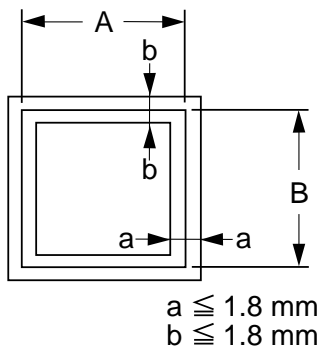

• **Focus adjustment**

Adjust the focus volume 1 and 2 for the optimum focus.

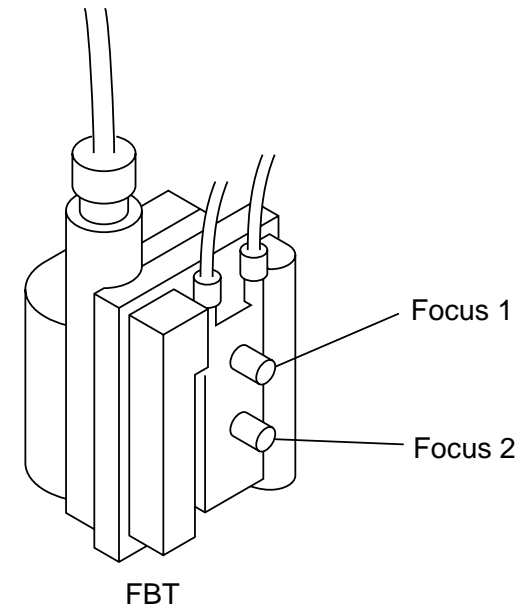

SECTION 4 DIAGRAMS

4-1. BLOCK DIAGRAMS

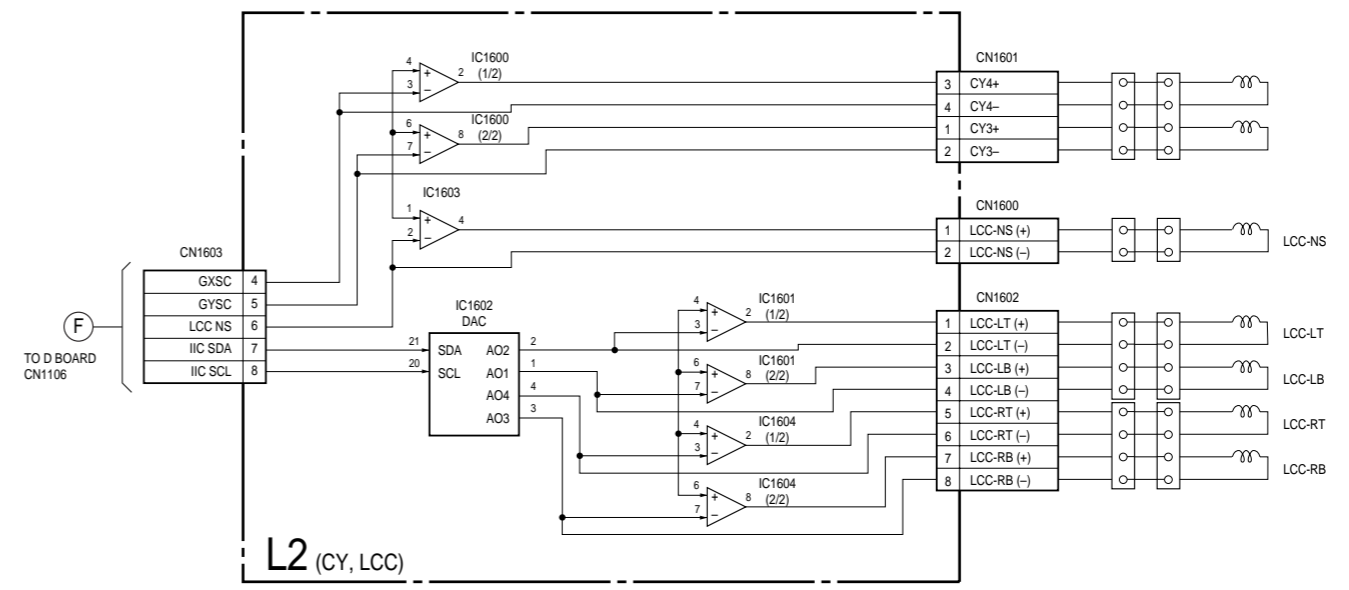
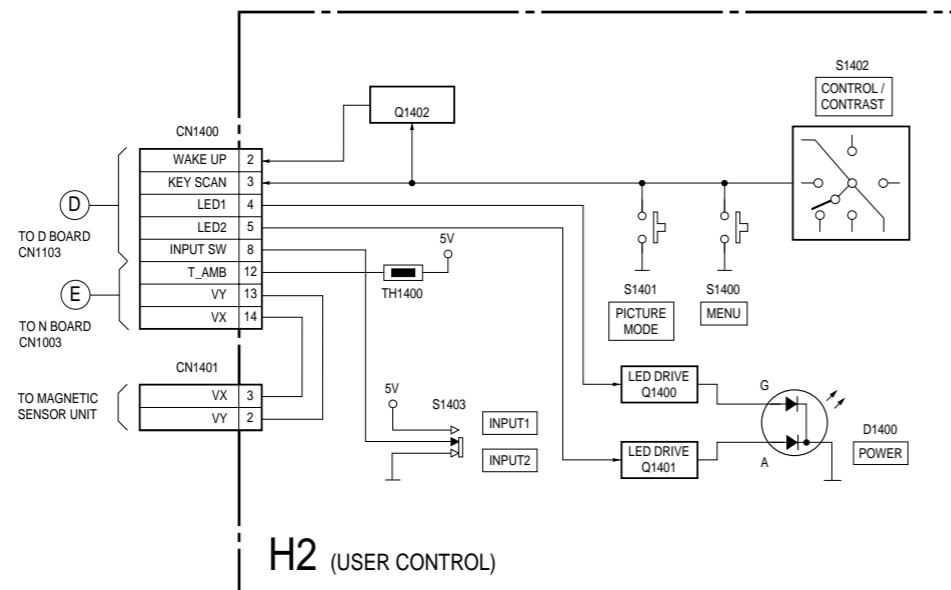
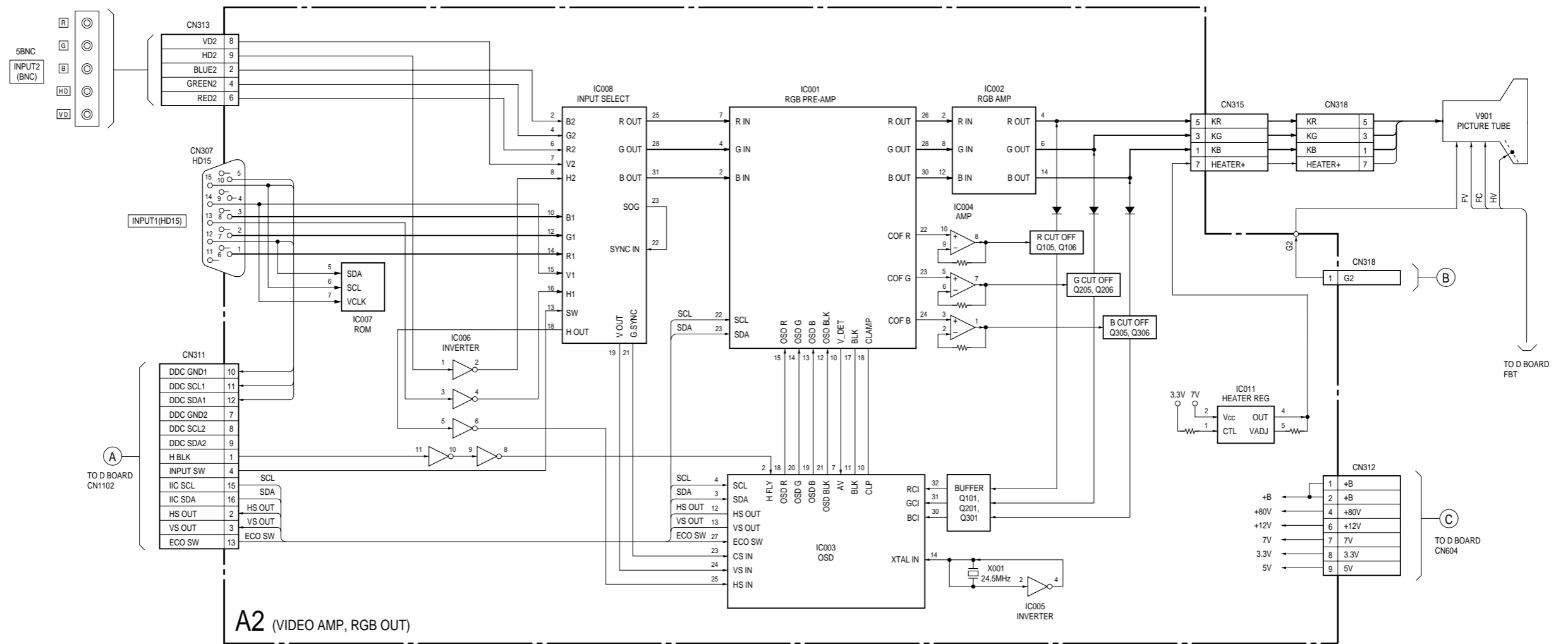

B-S3541<L>->-BD1-EPS05

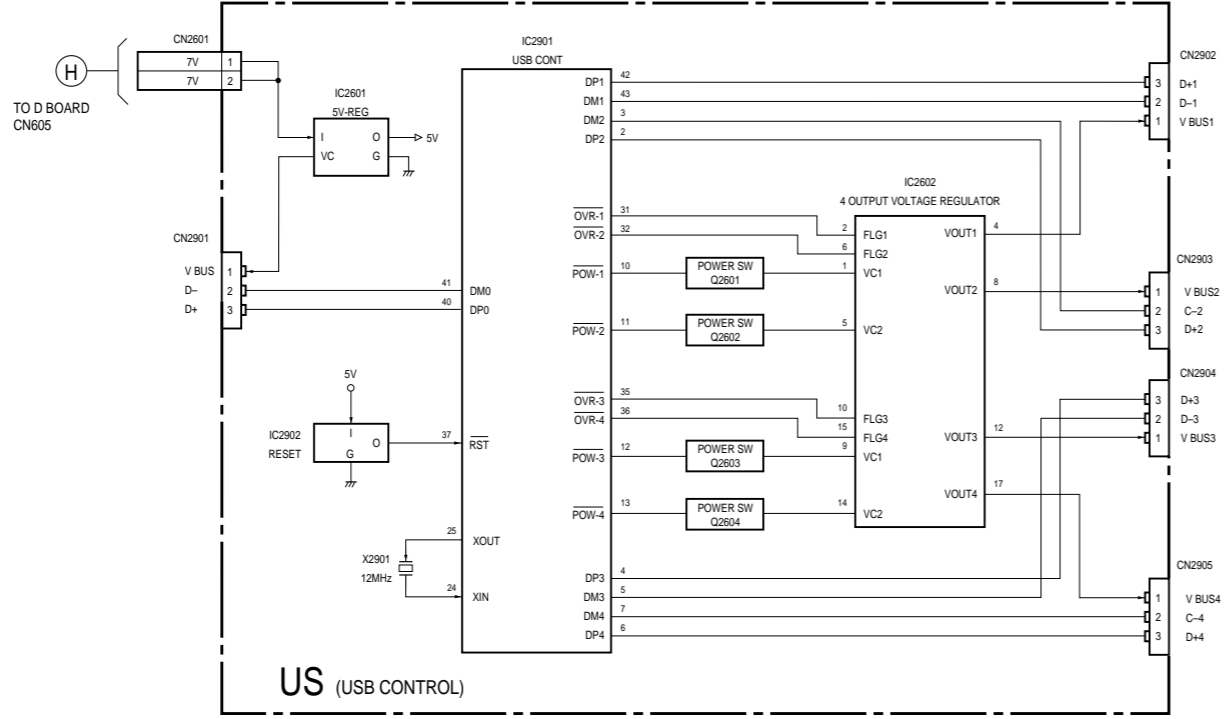
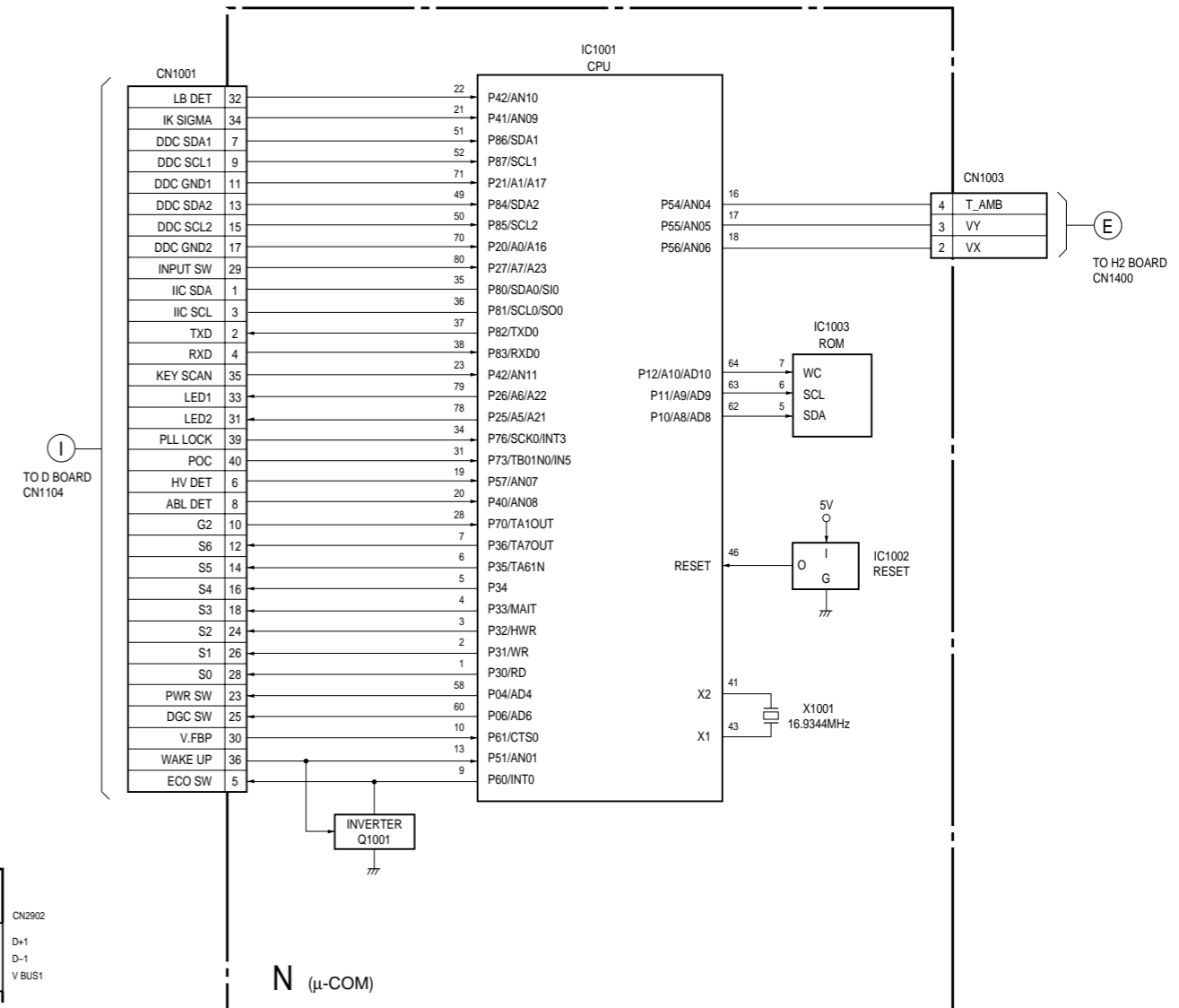
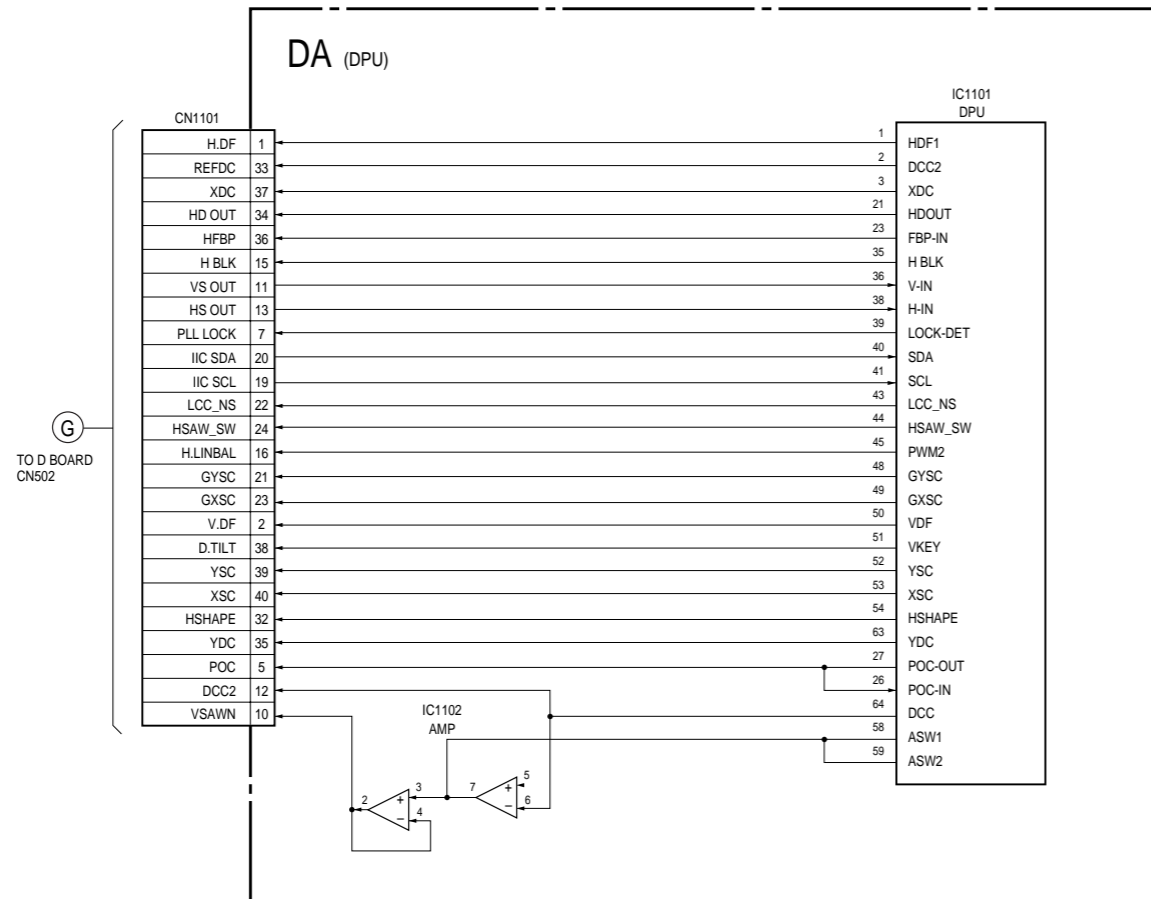

D (DEFLECTION, HDF, VDF, HV, POWER SUPPLY)

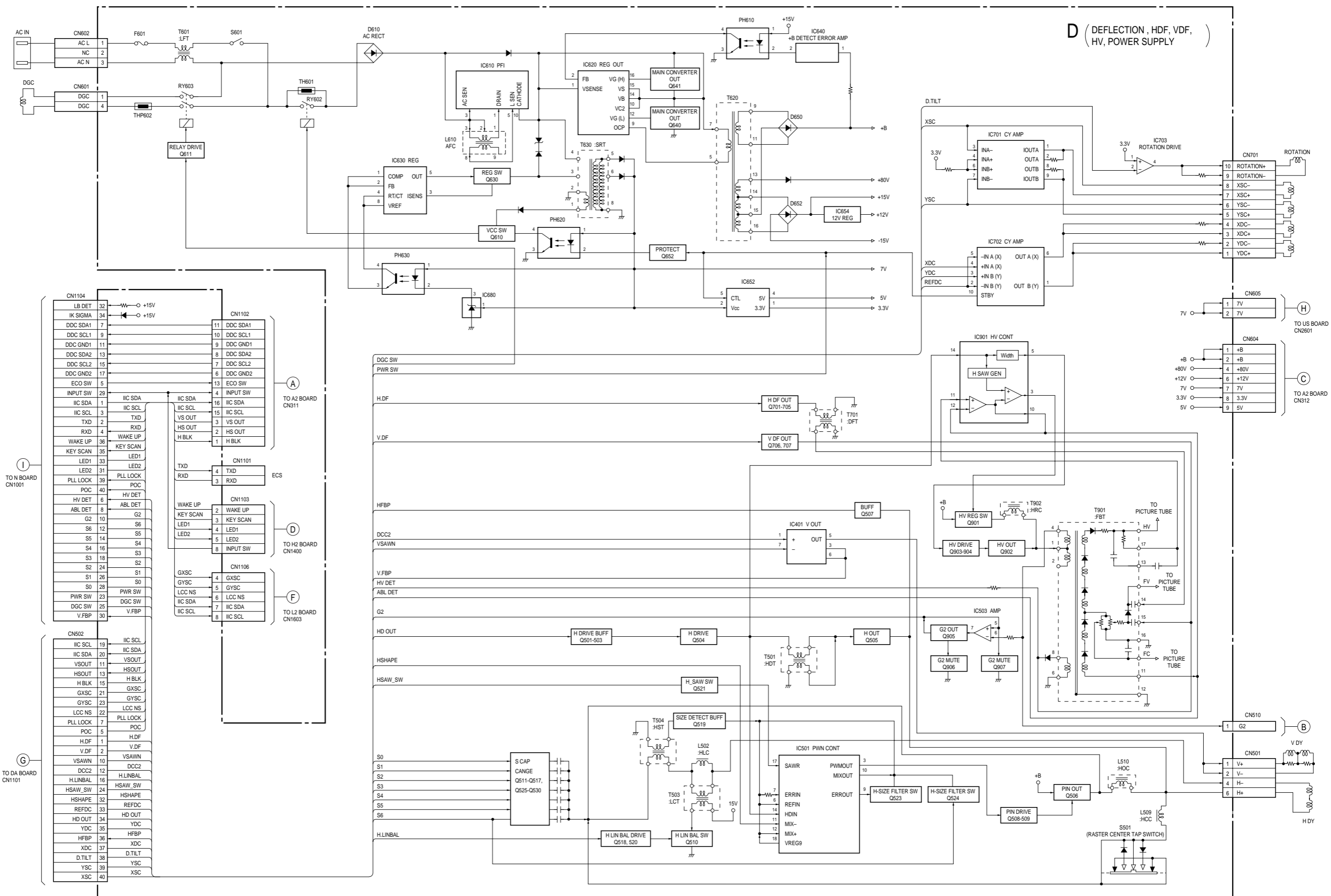

B-S53541<J>-BD3-EP905

4-2. FRAME SCHEMATIC DIAGRAM

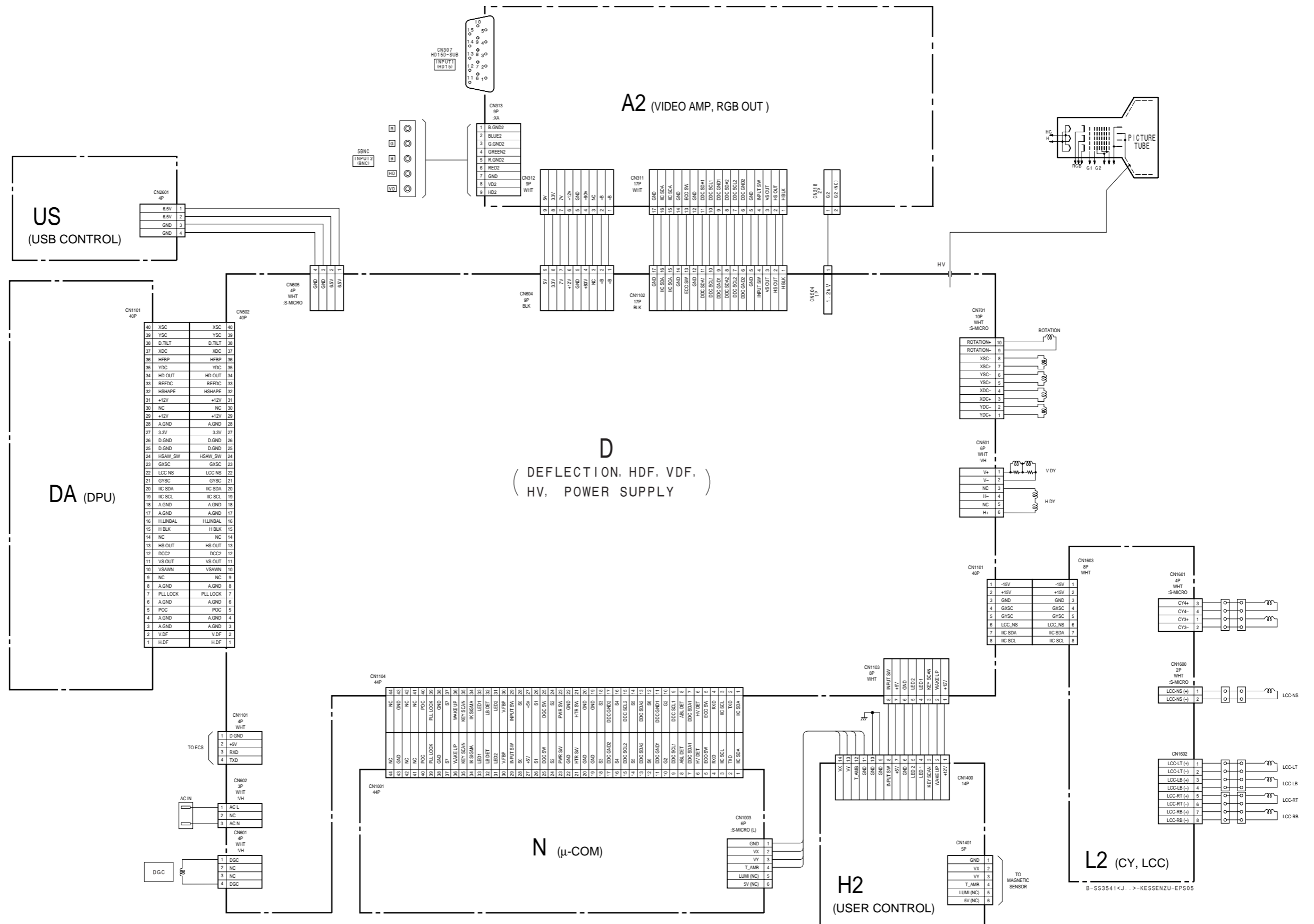

4-3. CIRCUIT BOARDS LOCATION

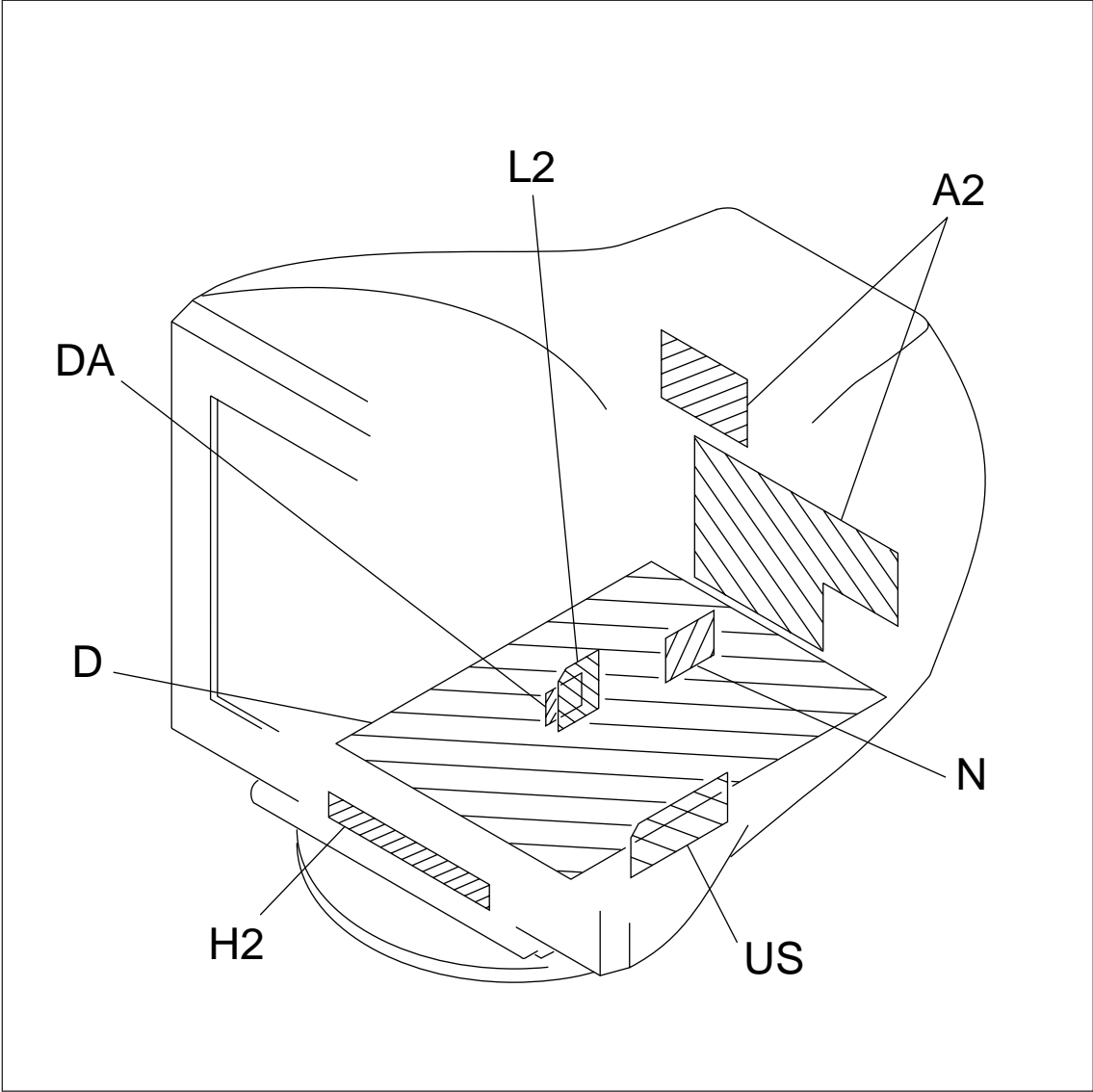









4-4. SCHEMATIC DIAGRAMS AND PRINTED WIRING BOARDS

Note:

- All capacitors are in μF unless otherwise noted. (pF: $\mu\mu\text{F}$)
Capacitors without voltage indication are all 50 V.
- Indication of resistance, which does not have one for rating electrical power, is as follows.

Pitch: 5 mm

Rating electrical power 1/4 W (CHIP : 1/10 W)

- All resistors are in ohms.
-  : nonflammable resistor.
-  : fusible resistor.
- Δ : internal component.
-  : panel designation, and adjustment for repair.
- All variable and adjustable resistors have characteristic curve B, unless otherwise noted.
- \perp : earth-ground.
-  : earth-chassis.
- The components identified by  in this basic schematic diagram have been carefully factory-selected for each set in order to satisfy regulations regarding X-ray radiation.
Should replacement be required, replace only with the value originally used.
- When replacing components identified by , make the necessary adjustments indicated. (See page 2-1)
- When replacing the part in below table, be sure to perform the related adjustment.
- All voltages are in V.
- Readings are taken with a 10 M digital multimeter.
- Readings are taken with a color-bar signal input.
- Voltage variations may be noted due to normal production tolerances.
- * : Can not be measured.
- Circled numbers are waveform references.
-  : B + bus.
-  : B - bus.

Note: The components identified by shading and mark Δ are critical for safety. Replace only with part number specified.

Note: Les composants identifiés par un tramé et une marque Δ sont critiques pour la sécurité. Ne les remplacer que par une pièce portant le numéro spécifié.

- Divided circuit diagram

One sheet of D board circuit diagram is divided into three sheets, each having the code D- $\text{\textcircled{a}}$ to D- $\text{\textcircled{c}}$. For example, the destination $\text{\textcircled{ab1}}$ on the code D- $\text{\textcircled{a}}$ sheet is connected to $\text{\textcircled{ab1}}$ on the D- $\text{\textcircled{b}}$ sheet.

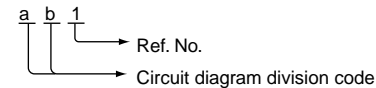

	Part Replaced (☒)
HV ADJ	RV901

	Part Replaced (☑)	
HV Regulator Circuit Check	D Board	C925, IC901, R901, R902, R905, R924, R925, R926, RV901, T901 (FBT) • Mounted D Board
	N Board	IC1001, RB1001 • Mounted N Board
HV Protector Circuit Check	D Board	C920, C923, D911, D912, R903, R917, R918, R919, R920, R923, T901 (FBT) • Mounted D Board
	N Board	IC1001, RB1001 • Mounted N Board
Beam Current Protector Circuit Check	D Board	C930, D917, R921, R932, R933, R935, T901 (FBT) • Mounted D Board
	N Board	IC1001, RB1001 • Mounted N Board

Terminal name of semiconductors in silk screen printed circuit (*)

	Device	Printed symbol	Terminal name	Circuit
①	Transistor		Collector Base Emitter	
②	Transistor		Collector Base Emitter	
③	Diode		Cathode Anode	
④	Diode		Cathode Anode (NC)	
⑤	Diode		Cathode Anode (NC)	
⑥	Diode		Common Anode Cathode	
⑦	Diode		Common Anode Cathode	
⑧	Diode		Common Anode Anode	
⑨	Diode		Common Anode Anode	
⑩	Diode		Common Cathode Cathode	
⑪	Diode		Common Cathode Cathode	
⑫	Diode		Anode Anode Cathode Anode	
⑬	Transistor (FET)		Drain Source Gate	
⑭	Transistor (FET)		Drain Source Gate	
⑮	Transistor (FET)		Source Drain Gate	
⑯	Transistor		Emitter Collector Base	
—	Discrete semiconductot			

(Chip semiconductors that are not actually used are included.)

Ver.1.6

(1) Schematic Diagram of A2 Board

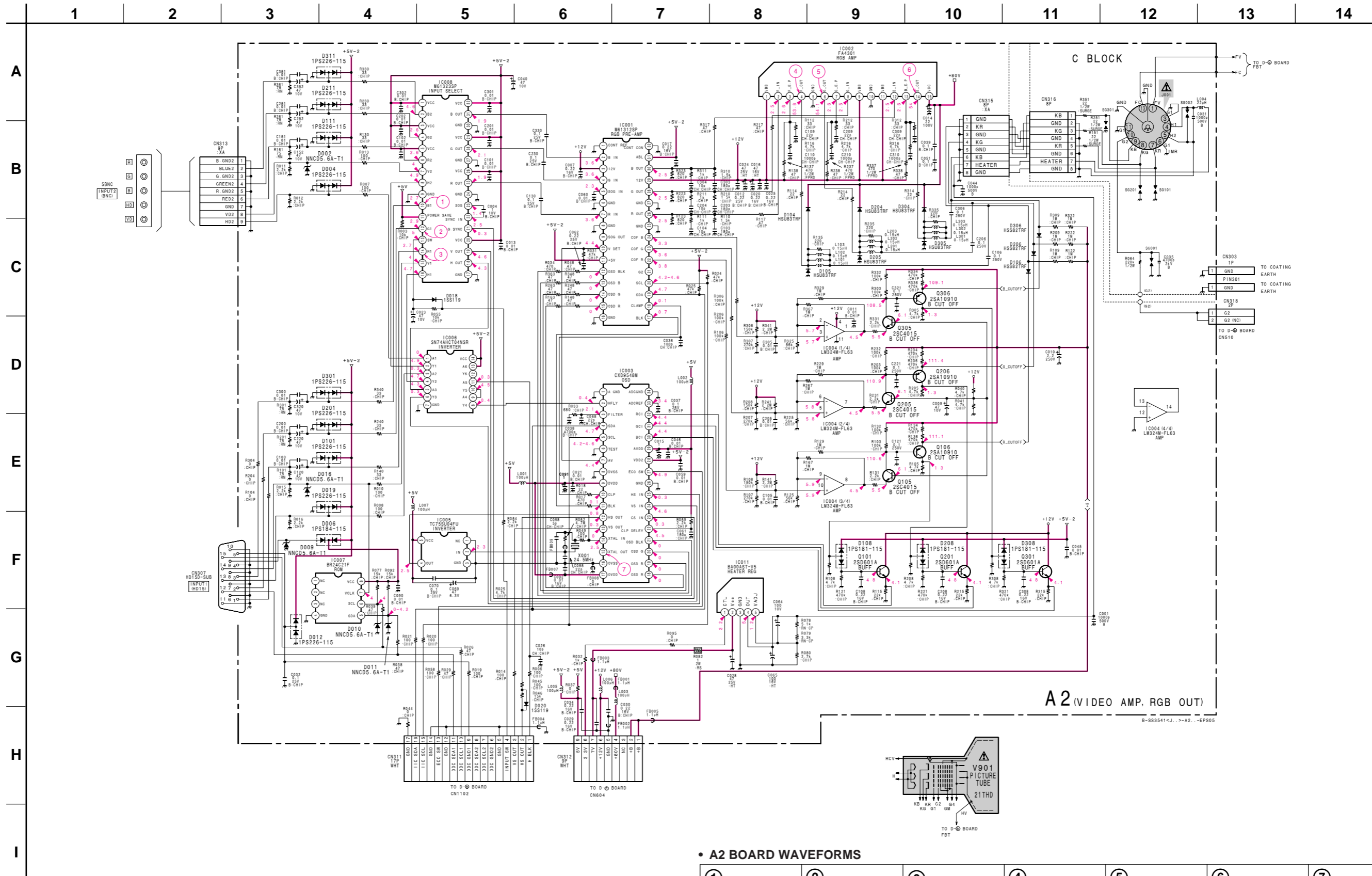

• A2 BOARD WAVEFORMS

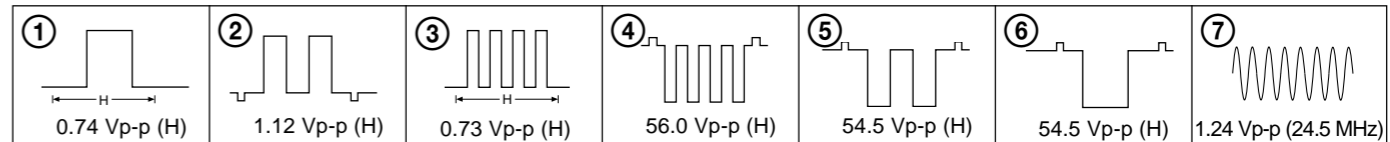

— A2 BOARD (Conductor Side) —

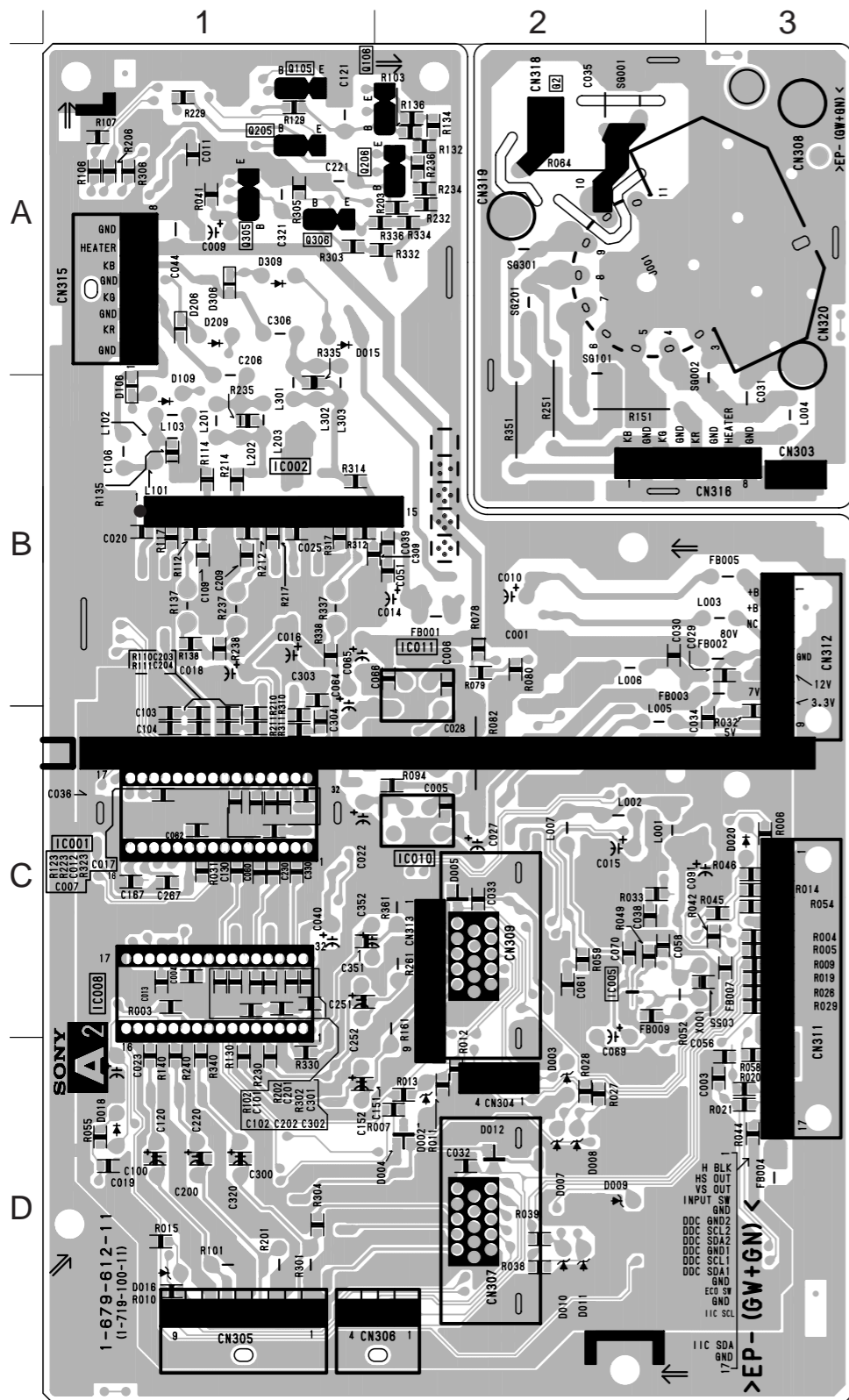

NOTE:
The circuit indicated as left contains high voltage of over 600 Vp-p. Care must be paid to prevent an electric shock in inspection or repairing.

— A2 BOARD (Component Side) —

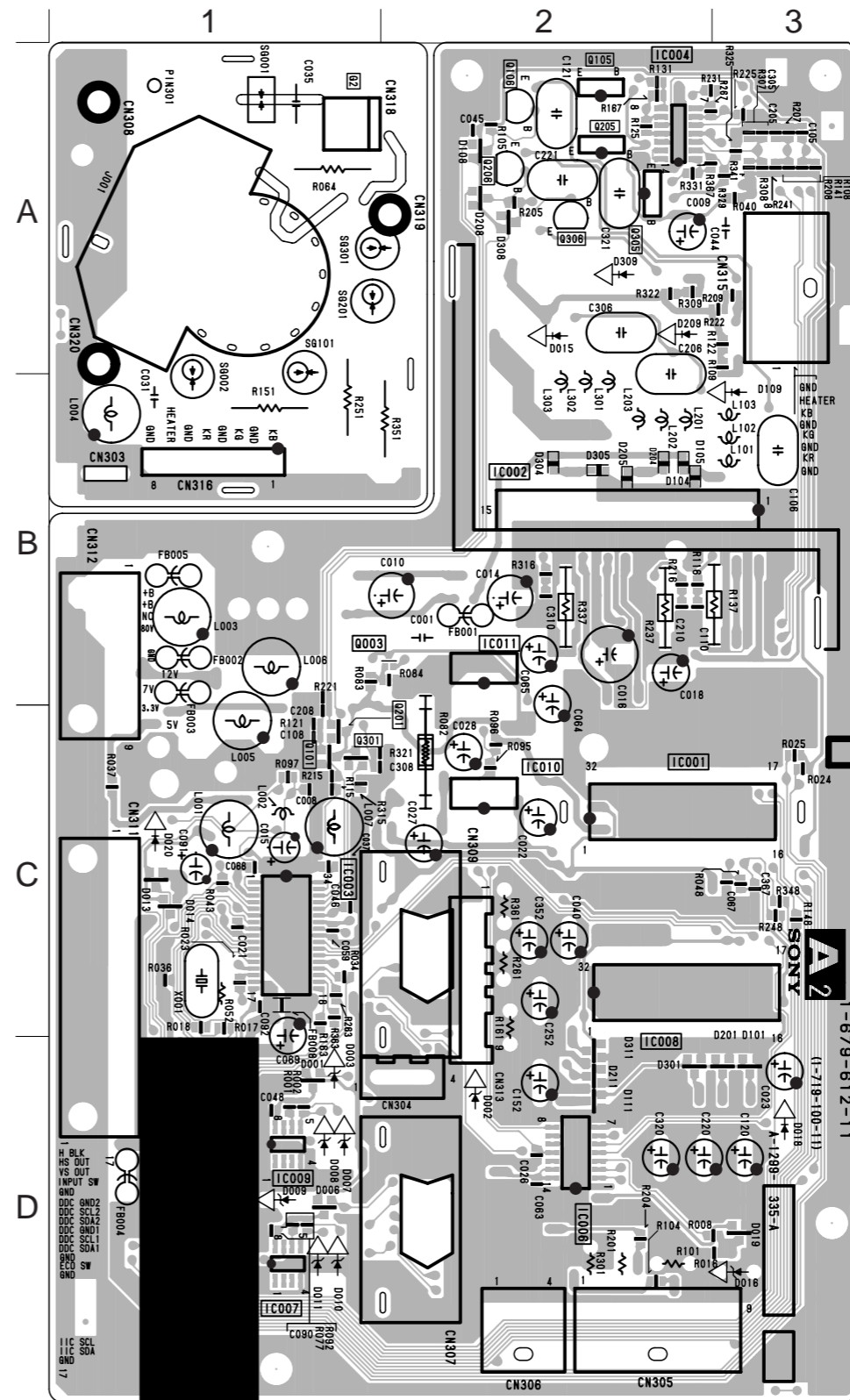

• A2 BOARD
SEMICONDUCTOR
LOCATION

IC	(Conductor Side) (Component Side)	
	(Conductor Side)	(Component Side)
IC001	C-1	C-2
IC002	B-1	B-2
IC003		C-1
IC004		A-2
IC005	C-2	
IC006		D-2
IC007		D-1
IC008	C-1	C-2
IC011	B-2	B-2

TRANSISTOR	(Conductor Side) (Component Side)		*
	(Conductor Side)	(Component Side)	
Q101		C-1	1
Q105	A-1	A-2	-
Q106	A-2	A-2	-
Q201		C-1	1
Q205	A-1	A-2	-
Q206	A-2	A-2	-
Q301		C-1	1
Q305	A-1	A-2	-
Q306	A-1	A-2	-

DIODE	(Conductor Side) (Component Side)		*
	(Conductor Side)	(Component Side)	
D002	D-2	D-2	-
D004	D-2		6
D006		D-1	9
D009	D-2	D-1	-
D010	D-2	D-1	-
D011	D-2	D-1	-
D012	D-2		6
D016	D-1	D-3	-
D018	D-1	D-3	-
D019		D-3	7
D020	C-3	C-1	-
D101		D-3	7
D104		B-2	3
D105		B-2	3
D106	B-1		3
D108		A-2	qa
D111		D-2	7
D201		D-3	7
D204		B-2	3
D205		B-2	3
D206	A-1		3
D208		A-2	qa
D211		D-2	7
D301		D-2	7
D304		B-2	3
D305		B-2	3
D306	A-1		3
D308		A-2	qa
D311		D-2	7

CRYSTAL	(Conductor Side) (Component Side)	
	(Conductor Side)	(Component Side)
X001	C-3	C-1

*: Refer to Terminal name of semiconductors in silk screen printed circuit (see page 4-7)

(2) Schematic Diagrams of D (a), (b), (c) Board

- Divided circuit diagram

One sheet of D board circuit diagram is divided into three sheets, each having the code D-**(a)** to D-**(c)**. For example, the destination **(ab1)** on the code D-**(a)** sheet is connected to **(ab1)** on the D-**(b)** sheet.

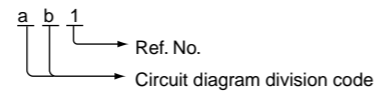

• D-(a) BOARD WAVEFORMS

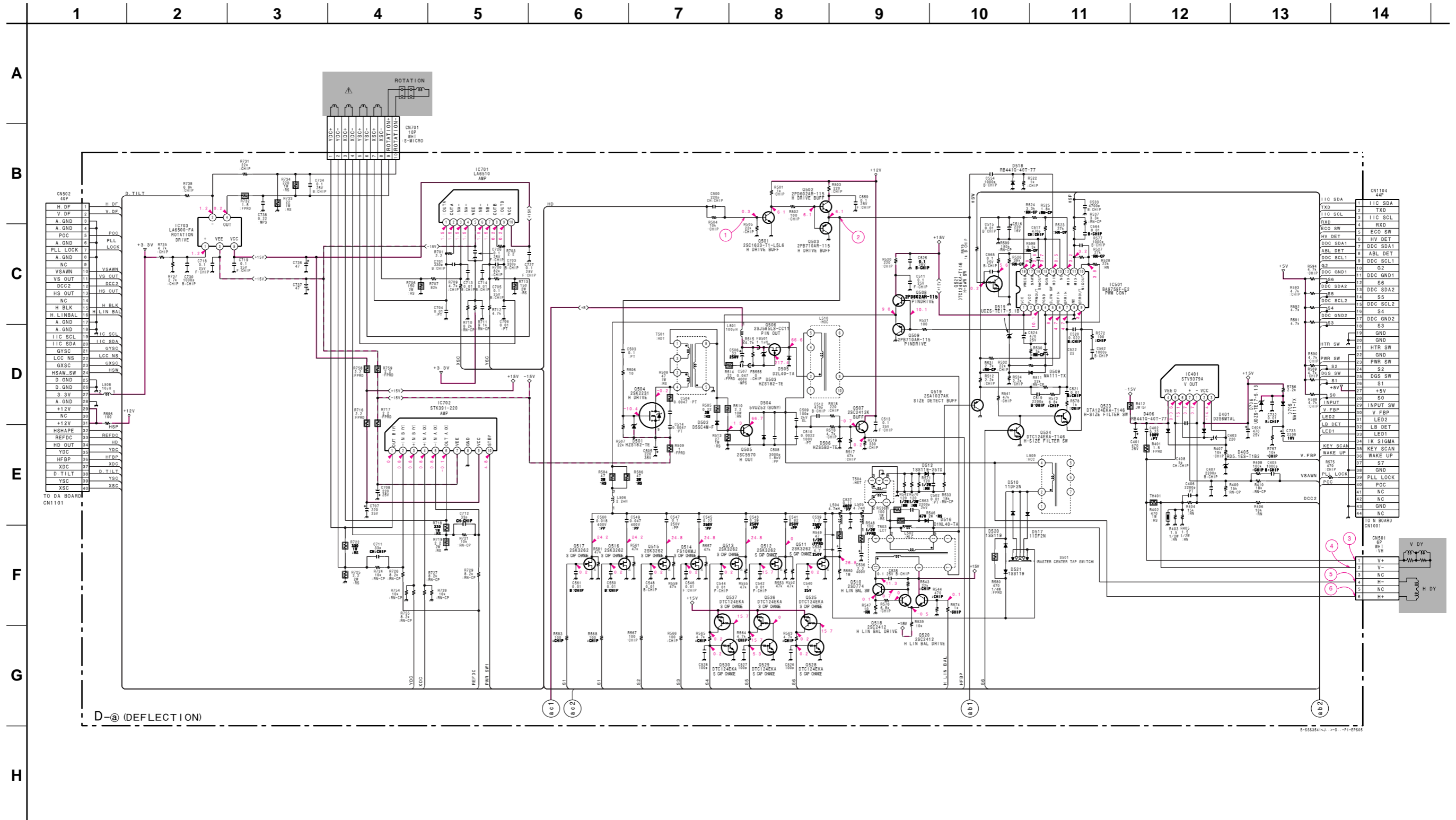
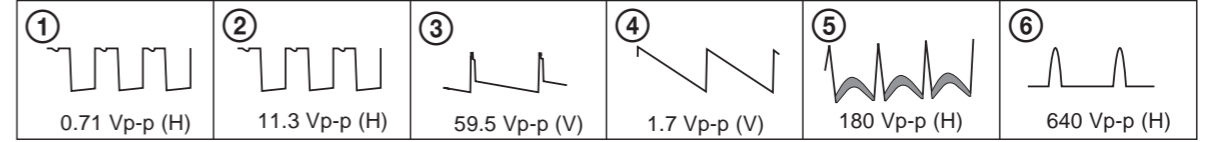

B-8883641-J ->D -P1-EP05

(3) Schematic Diagram of DA Board

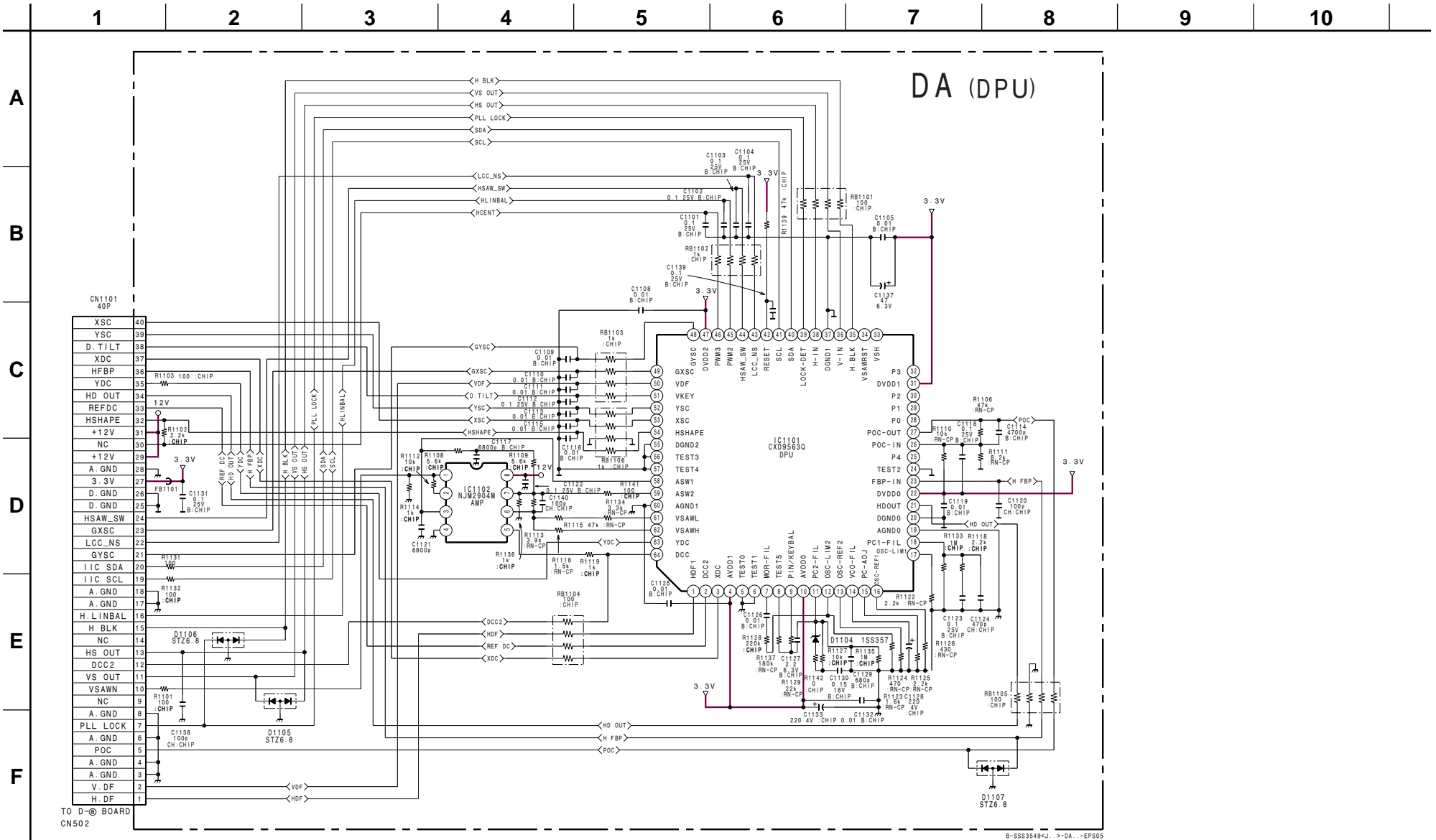

TO D-BOARD
CN502

B-SS83549CJ...-DA...-EPS05

— DA BOARD (Conductor Side) —

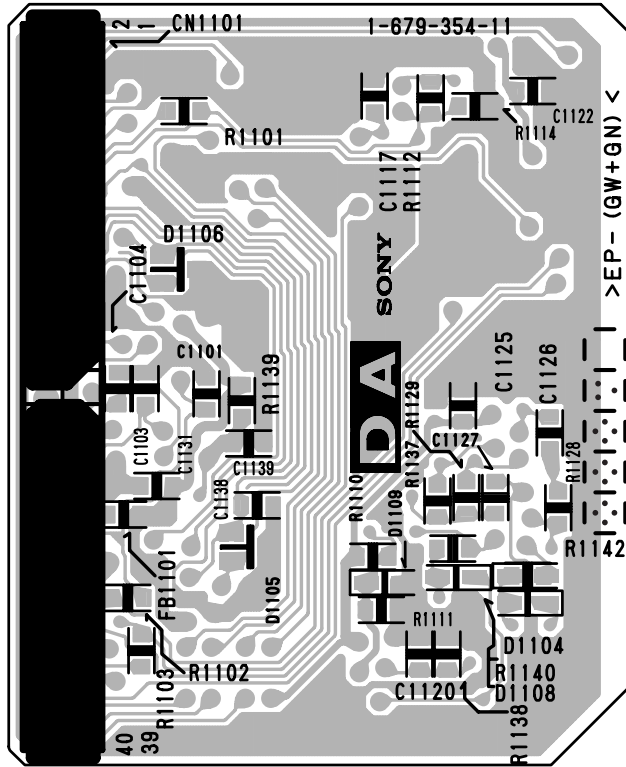

— DA BOARD (Component Side) —

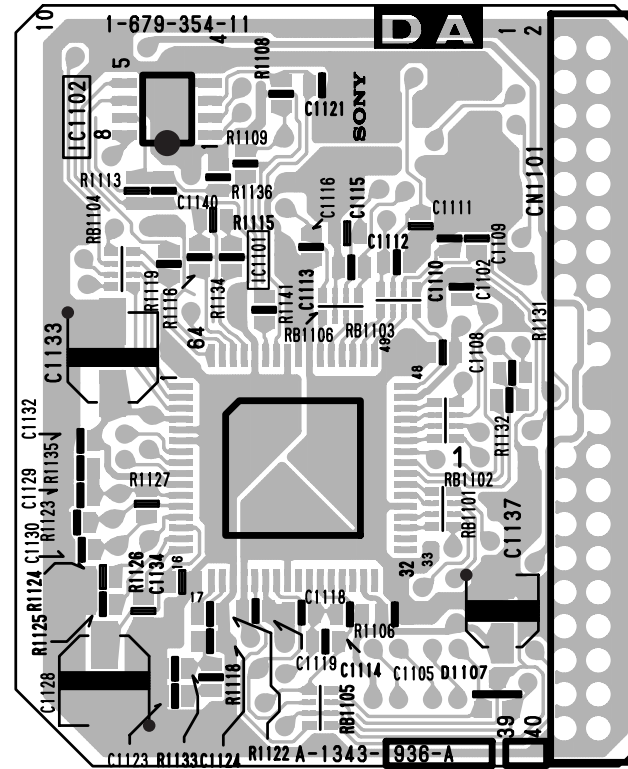

DA BOARD

Terminal name of semiconductors in silk screen printed circuit (*)

Ref.	*
D1104	③
D1105 - D1107	⑩

*: Refer to Terminal name of semiconductors in silk screen printed circuit (see page 4-7)

(4) Schematic Diagram of H2 Board

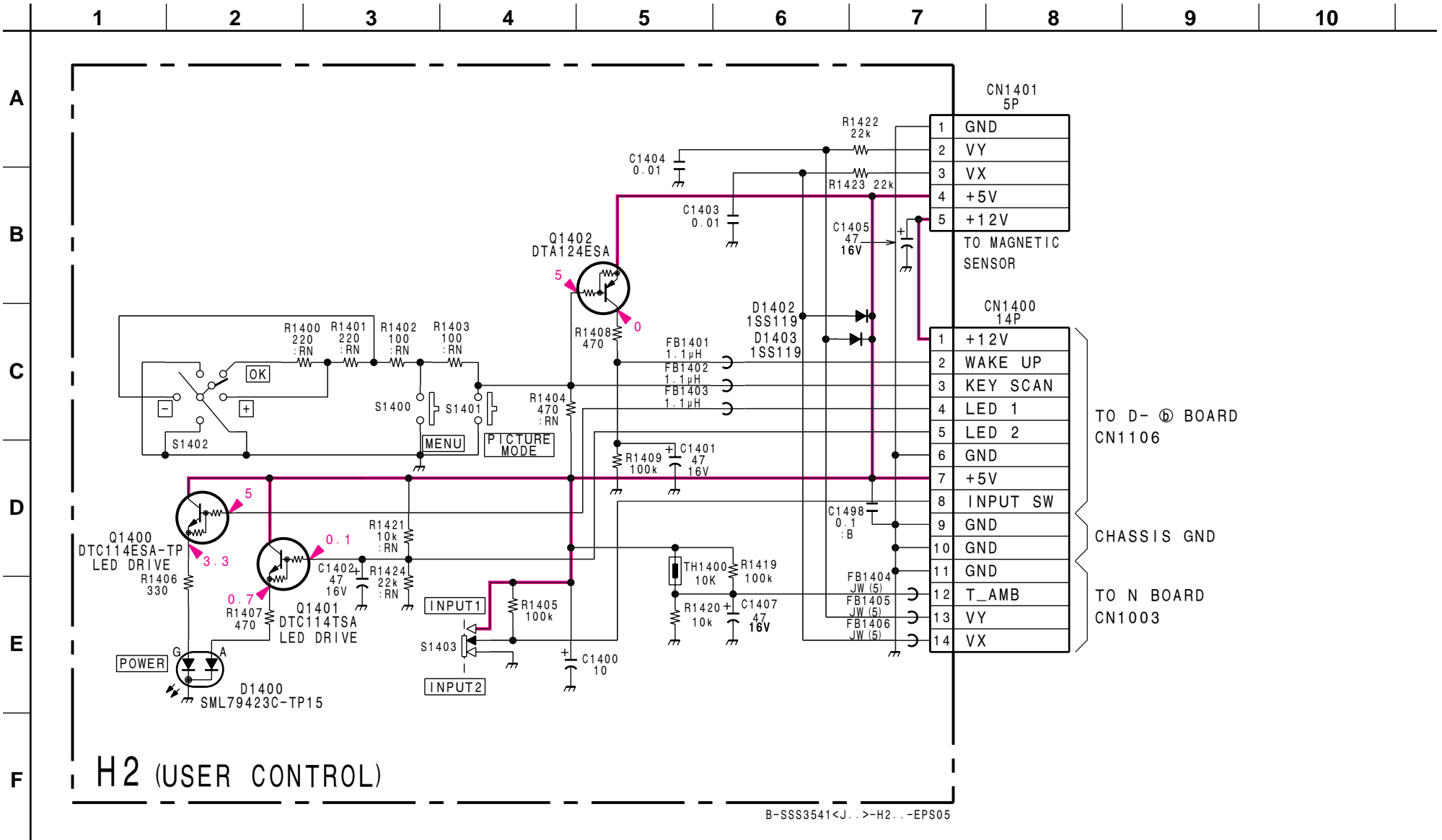

(5) Schematic Diagram of L2 Board

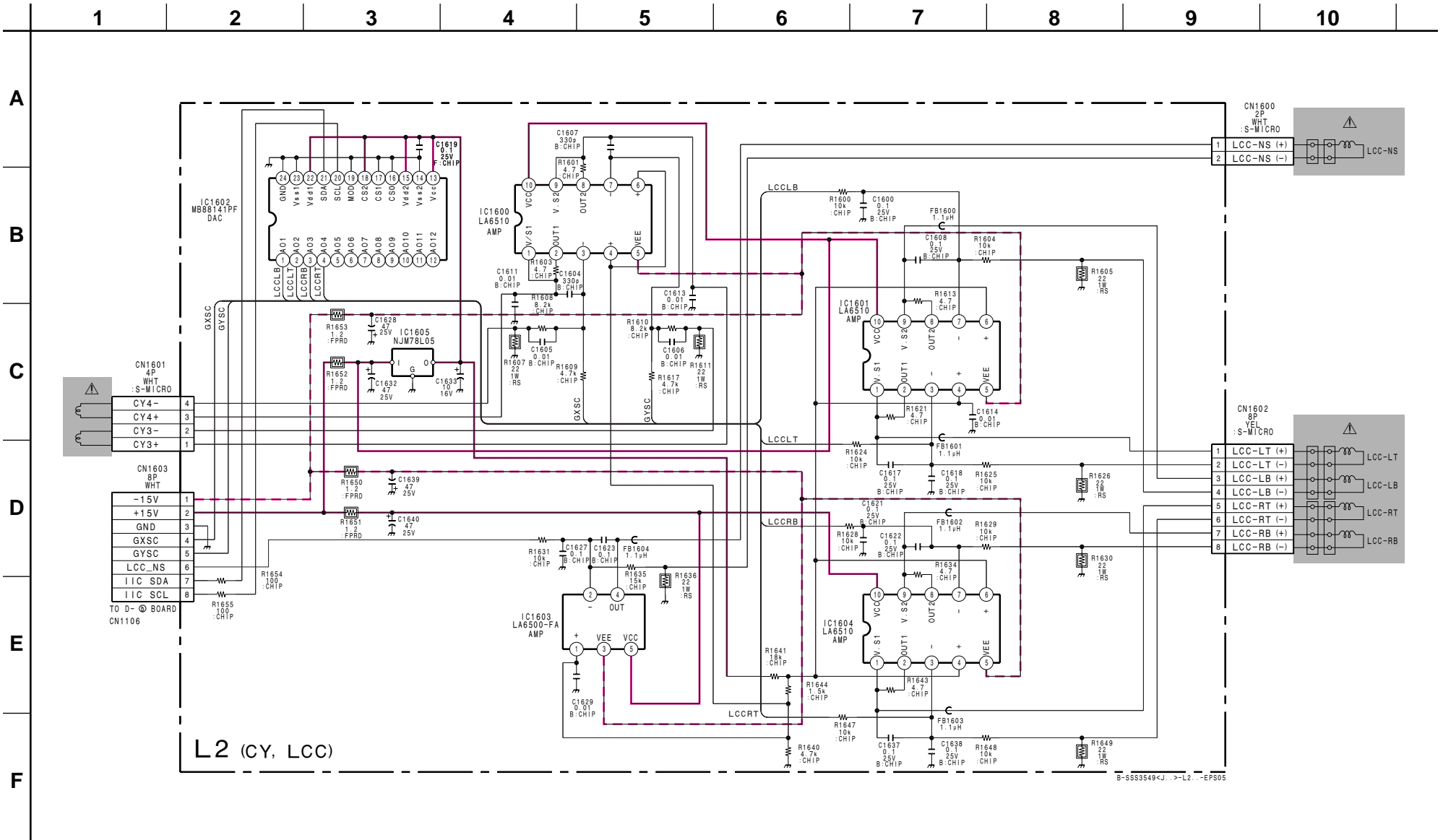

— L2 BOARD (Conductor Side) —

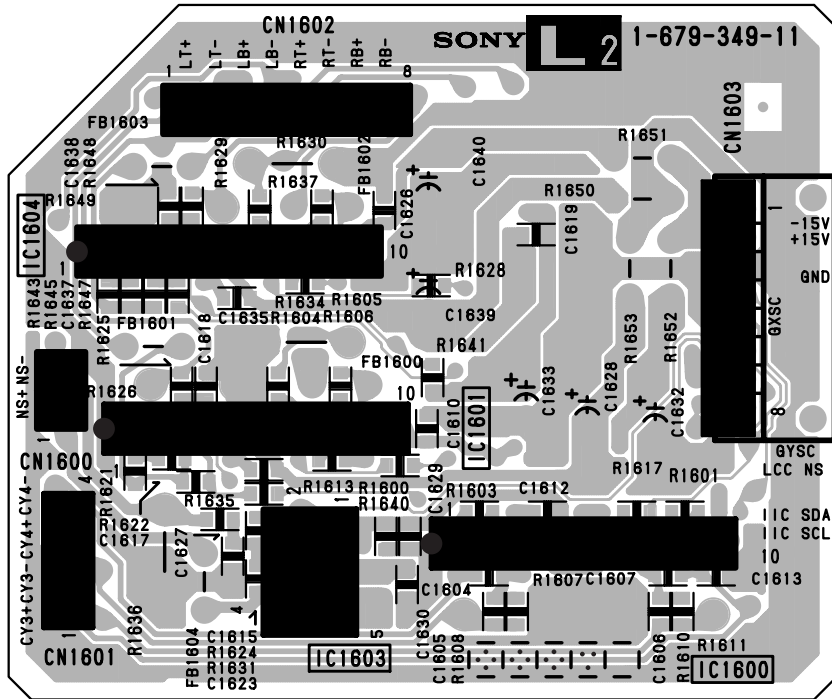

— L2 BOARD (Component Side) —

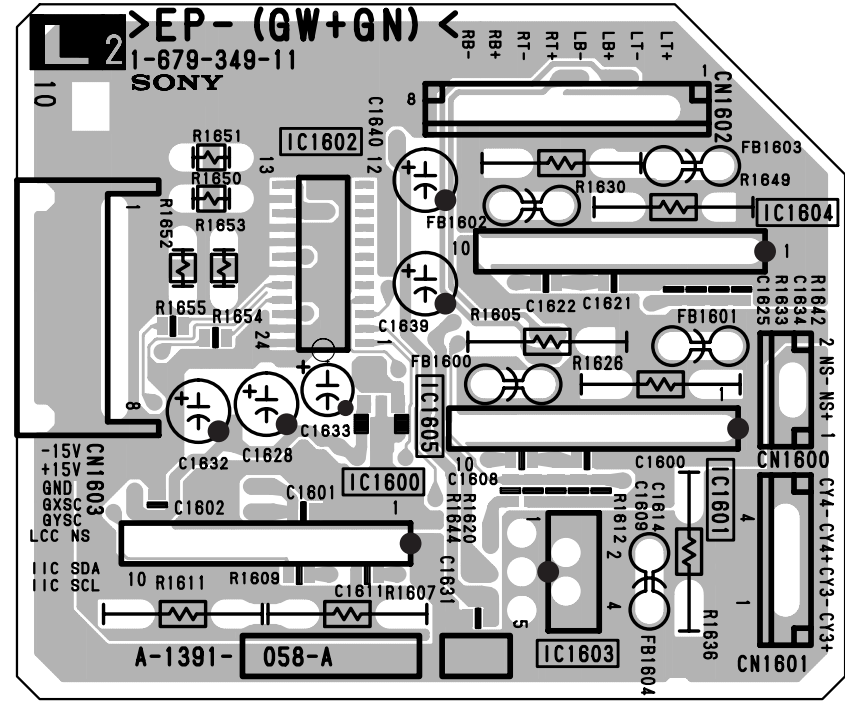

(7) Schematic Diagram of US Board

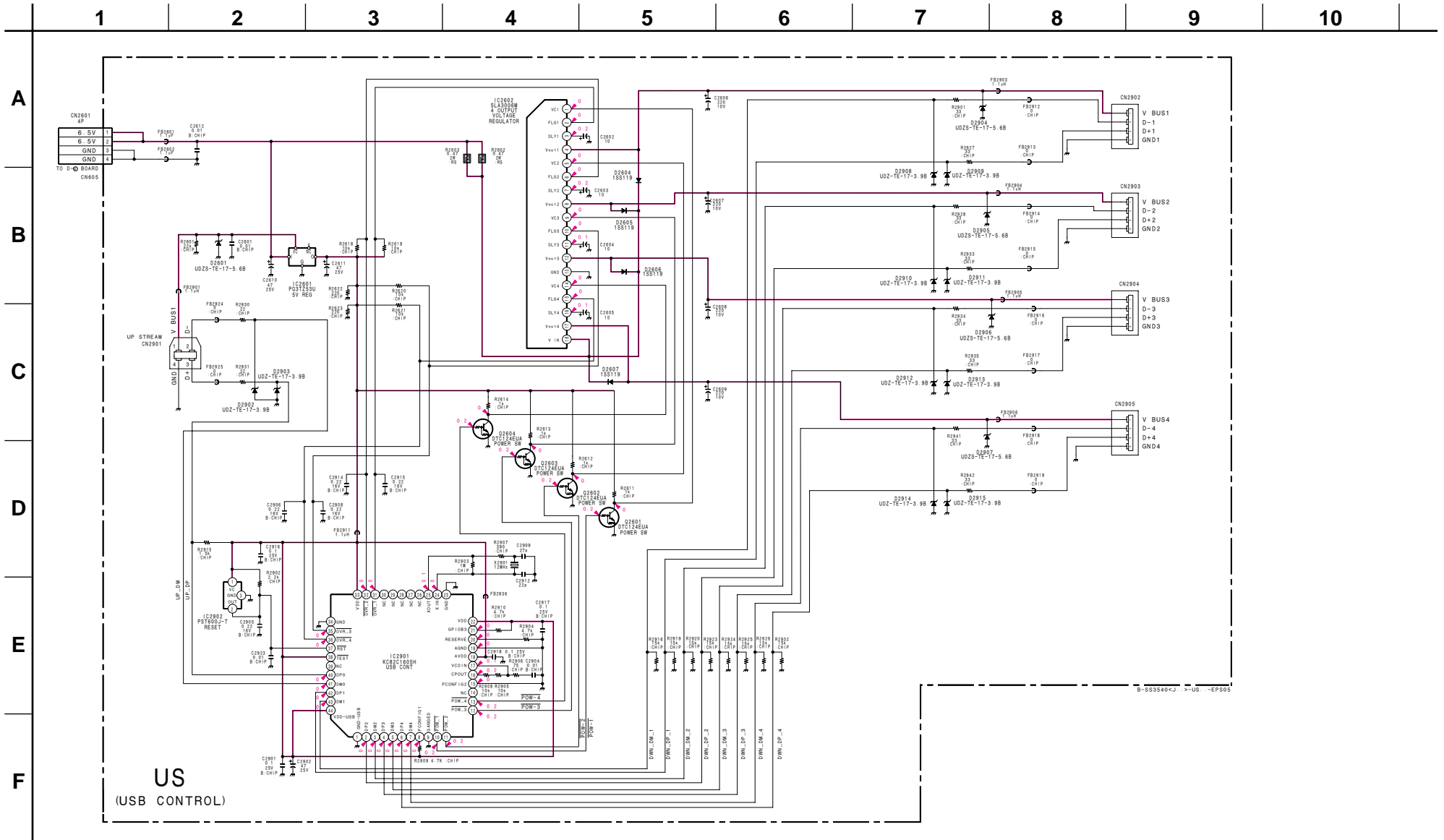

— US BOARD (Conductor Side) —

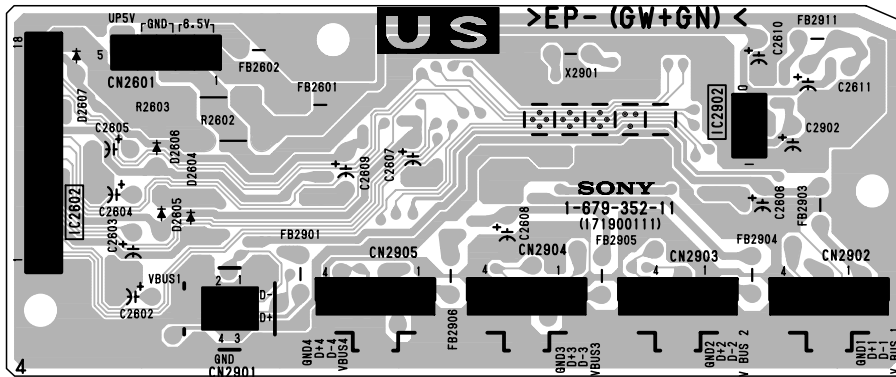

— US BOARD (Component Side) —

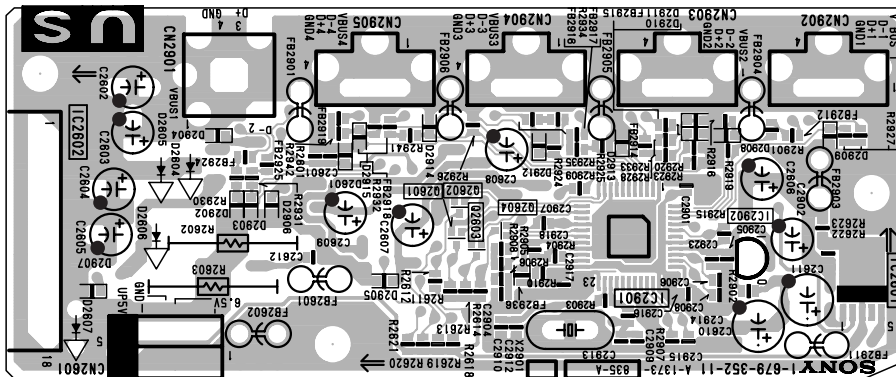

US BOARD

Terminal name of semiconductors
in silk screen printed circuit (*)

Ref.	*
D2601, D2902 - D2915	③
Q2601 - Q2604	②

※: Refer to Terminal name of semiconductors
in silk screen printed circuit (see page 4-7)

4-5. SEMICONDUCTORS

**BA00AST-V5
LA6500-FA**

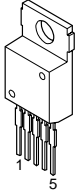

**BR24C16F-E2
BR24C21F-E2
NJM2904M
NJM2904M(TE2)**

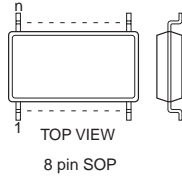

FA4301

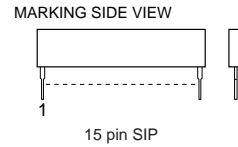

MM1431ATT

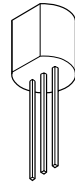

**PQ3DZ53U
PQ3TZ53U**



**STV9379
STV9379A**

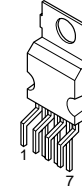

**DTA124ESA
DTA124ESA-TP
DTC114ESA
DTC114ESA-TP
DTC143XSA
DTC143XSA-TP**

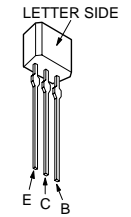

BA3953T-T5

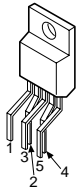

CXD9548M

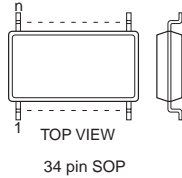

KC82C160SH

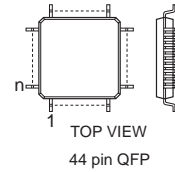

MZ1532

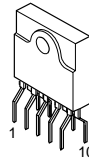

PST600J-T

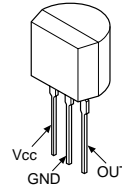

TC7SU04FU(TE85R)

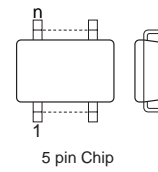

**DTA143ZSA-TP
DTC114TSA
DTC114TSA-TP**



**BA9758AFS-E2
BA9758FS-E2**

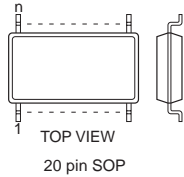

CXD9563Q

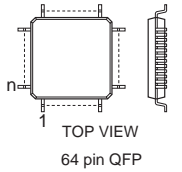

LA6510

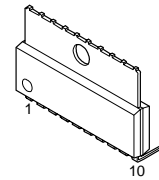

**M61312SP
M61323SP**

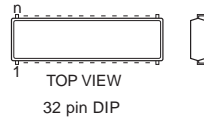

SLA3006M(LF874)

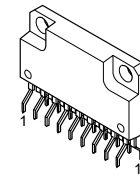

TMP91PW18F-1A22(Z)

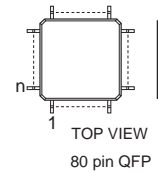

**DTC124EUA-T106
DTC124EUT106**

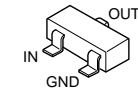

BA9759F-E2

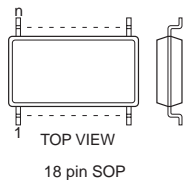

FA13842P

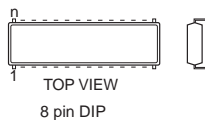

MB88141PF-ER

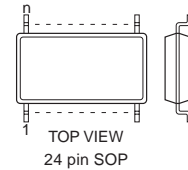

NJM78L05UA-TE1



**LM324M
LM324M-FL63
SN74AHCT04NSR**

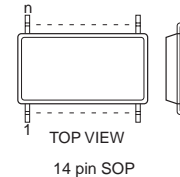

**DTA124EKA-T146
DTC124EK
DTC124EKA-T146
2PB710AR-115
2PD602AR-115
2SA1037AK-T146-QR
2SA1037AK-T146-R
2SA1162-G
2SB709A-QRS-TX
2SC1623-L5L6
2SC1623-T1-L5L6
2SC2412K-T-146-Q
2SC2412K-T-146-QR
2SD601A-Q
2SD601A-QRS-TX**

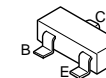

MCZ3001D

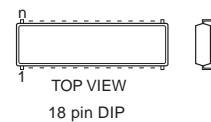

**NJM7812FA
SEB3-LF4**

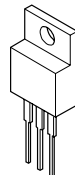

STK391-220

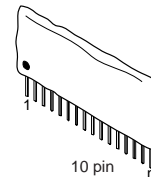

FS5KM-18A-AT
2SK2876-01MR-F122

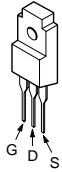

2SC4015TV2

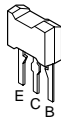

2SJ569LS-CB11
2SJ569LS-CC11
2SK3262-01MR-F119

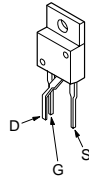

D1NL20U-TR
D1NL20U-TR2
D1NL40-TA
D1NL40-TA2
D2L40-TA
D2S6M
D2S6MTA1
ERA34-10TP1
ERB38-06V1
HSS82-TJ
HZS5B2-TE
NNCD5.6A-T1
P6KE200AG23
RGP02-17EL-6433
RGP02-17PKG23
RGP02-20EL-6394
11DF2N-TA2B2

HSU83TRF

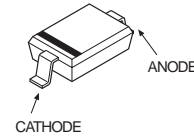

RM11A
RM11C

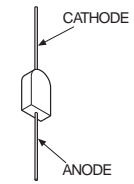

1PS226-115

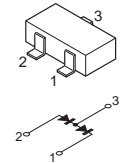

IRFU110
2SK2231

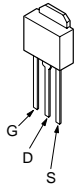

2SC4620TV2Q
2SD774-34
2SD774-T-34

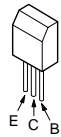

2SK2647-01MR-F91

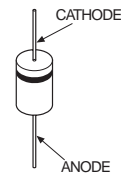
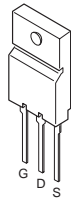

HZS182-TE
RB441Q-40T-77
RD15ES-B3
RD15ES-T1B3
RD18ESB
RD27ES-B2
RD27ES-T1B
RD5.1ES-T1B2
RD5.1ESB2
RD5.6ESB2
1SS119-25
1SS119-25TD

SML79423C-TP15

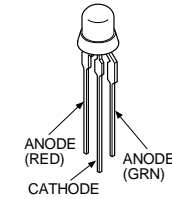

1SS376TE-17

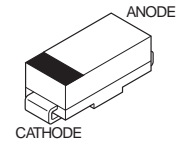

2SA1358-Y
2SC3421-Y

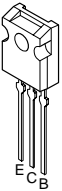

2SC4634LS-CB11

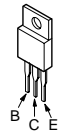

DTZ10B
DTZ13B
MA111-(K8).S0
MA111-TX
UDZ-TE-17-13B
UDZ-TE-17-3.9B
UDZS-TE17-10B
UDZS-TE17-5.1B
UDZS-TE17-5.6B
UDZS-TE17-9.1B
1SS357-TPH3

D10SC9M
D5SC4M-F

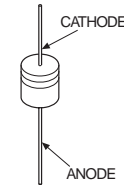
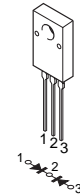

TLP421F(D4-SONY)

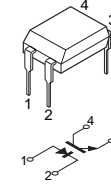

5VUZ52C(SONY)

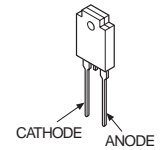

2SA1091-0
2SA10910-TPE2
2SC2362KF-AA
2SC2362K-G
2SC2362KG-AA

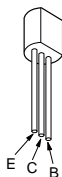

2SC5570(LBSONY2)

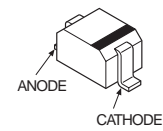
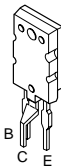

D4SB60L
D4SBL40
D4SBS4
D4SBS4-F

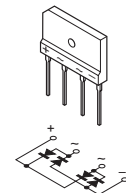

1PS184-115

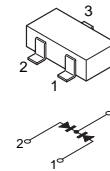

1PS181-115

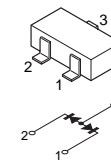

MA8039

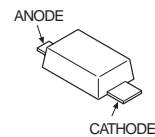

SECTION 5 EXPLODED VIEWS

- Items with no part number and no description are not stocked because they are seldom required for routine service.
- The construction parts of an assembled part are indicated with a collation number in the remark column.
- Items marked " * " are not stocked since they are seldom required for routine service. Some delay should be anticipated when ordering these items.

The components identified \triangle marked are critical for safety.
Replace only with the part number specified.

Les composants identifiés par la marque \triangle sont critiques pour la sécurité.
Ne les remplacer que par une pièce portant le numéro spécifié.

5-1. CHASSIS

- 7-685-872-09 +BVTT 3X8
- 7-685-663-71 +BVTP 4X16
- 7-685-881-09 +BVTT 4X8
- 7-685-647-79 +BVTP 3X10
- ▲ 7-685-880-09 +BVTT 4X6
- ◇ 7-685-646-79 +BVTP 3X8

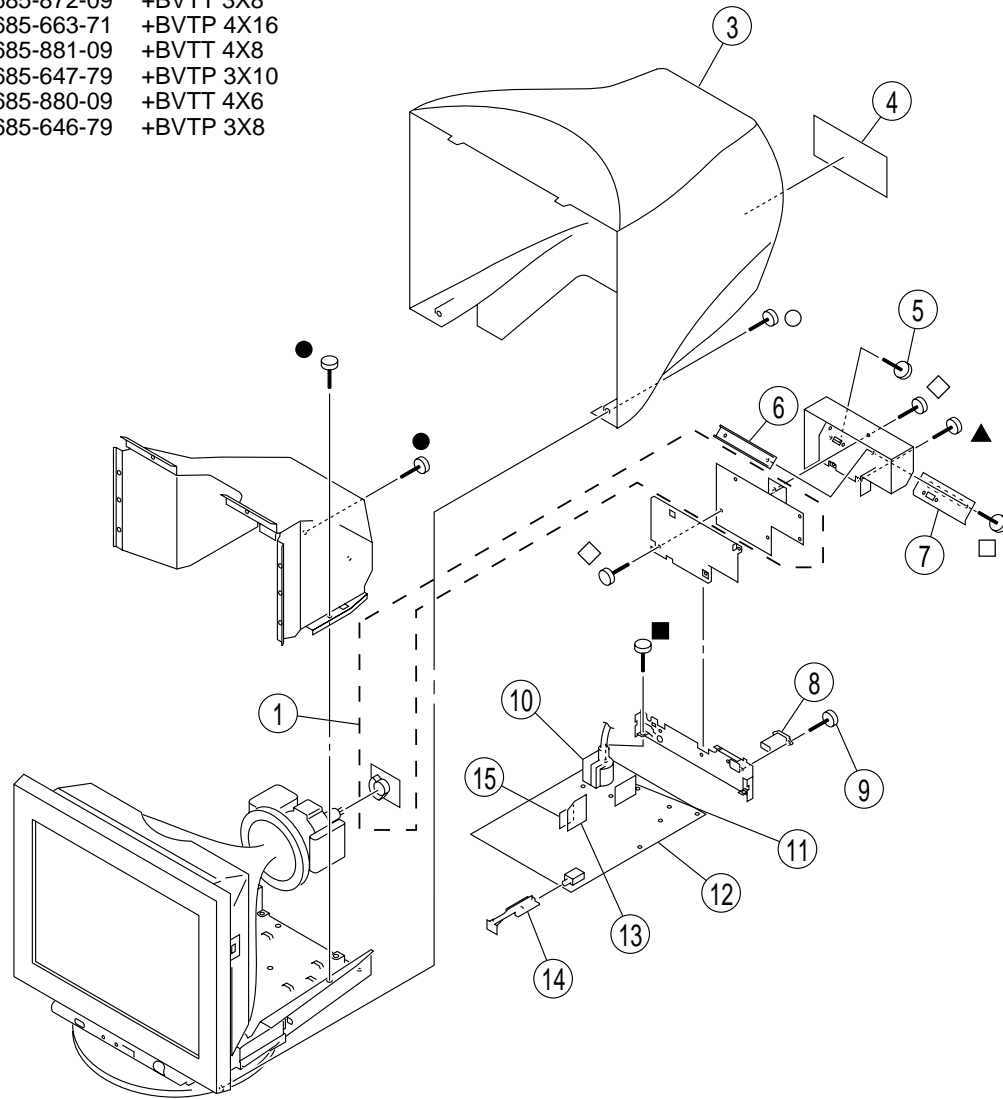

REF.NO.	PART NO.	DESCRIPTION	REMARK
1	* 8-933-473-00	A2 BOARD, COMPLETE	
3	X-4038-569-1	CABINET ASSY	
4	* 4-081-198-01	LABEL, INFORMATION [U/C]	
4	* 4-081-197-01	LABEL, INFORMATION [AEP]	
5	* 4-635-966-01	SCREW (HEX)	
6	1-694-763-11	TERMINAL BOARD ASSY, INPUT/OUT	
7	4-080-798-01	SEET, CONNECTOR	
8	△ 1-251-382-31	INLET, AC (WITH NOISE FILTER)	
9	4-052-345-01	SCREW, (3X8) (+K), TAPPING	
10	△ 1-453-359-11	TRANSFORMER ASSY, FLYBACK (NX4702/KM7E)	
11	* 8-933-479-00	N BOARD, COMPLETE	
12	* 8-933-475-00	D BOARD, COMPLETE	
13	* 8-933-481-00	L2 BOARD, COMPLETE	
14	4-079-799-01	BAR, EXTENSION	
15	* 8-933-476-00	DA BOARD, COMPLETE	

5-2. PICTURE TUBE

- 7-685-881-09 +BVTT 4X8
- 7-685-647-79 +BVTP 3X10
- 7-685-663-71 +BVTP 4X16
- △ 7-685-872-09 +BVTT 3X8

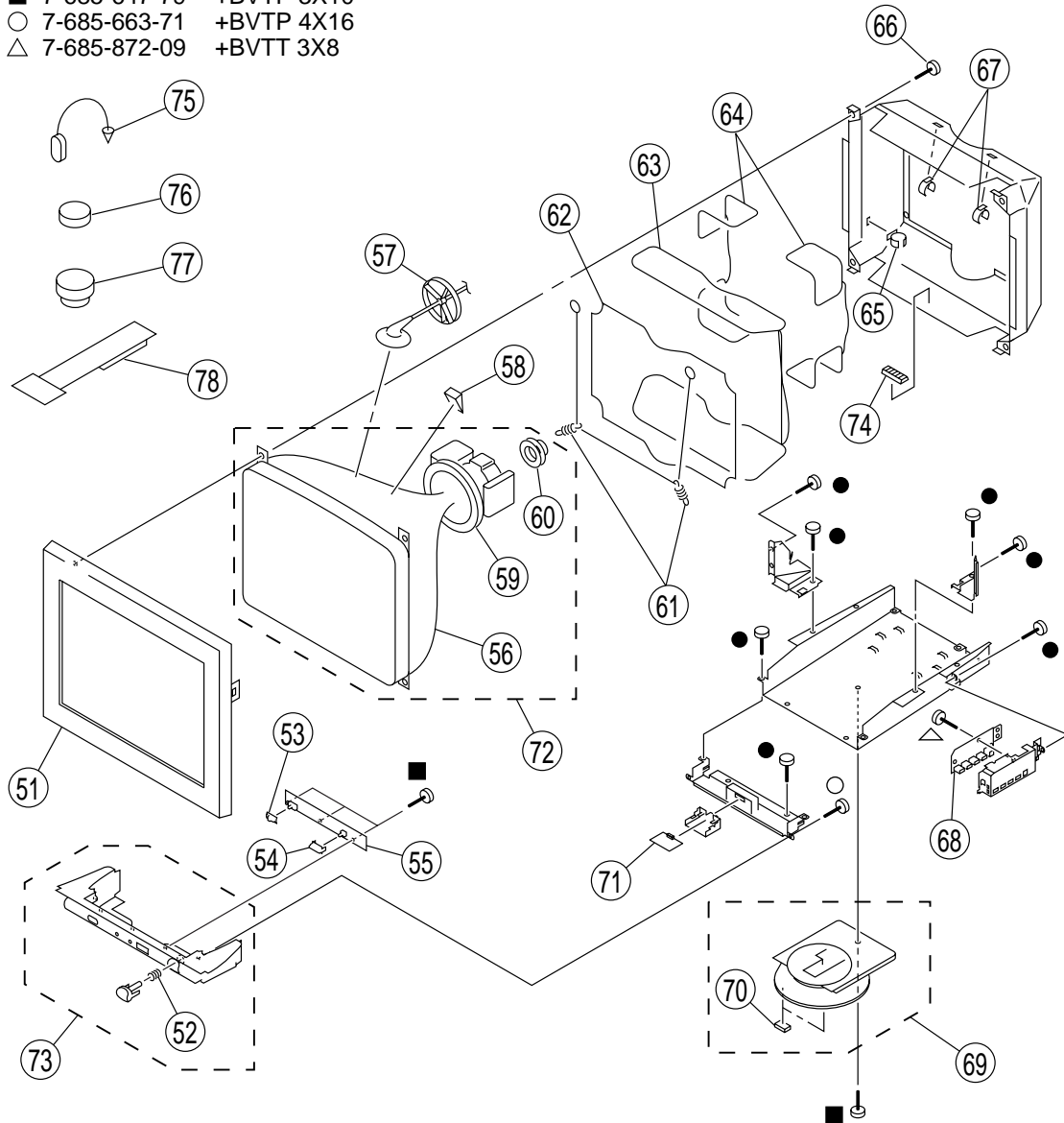

REF.NO.	PART NO.	DESCRIPTION	REMARK
51	4-080-801-01	BEZEL	
52	4-042-593-01	SPRING, COMPRESSION	
53	4-080-800-01	SELECTOR, INPUT	
54	4-080-799-01	BUTTON, MENU	
55	* 8-933-478-00	H2 BOARD, COMPLETE	
56	△ 8-738-840-05	PICTURE TUBE 21THD	
57	3-704-372-01	HOLDER, HV CABLE	
58	2-162-100-21	SPACER, DY	
59	△ 8-451-519-21	DEFLECTION YOKE (Y21TKN-M2)	
60	△ 1-452-912-71	NECK ASSEMBLY (NA-2914)	
61	* 4-047-316-01	SPRING, EXTENTION	
62	1-419-130-21	COIL, LANDING CORRECTION	
63	△ 1-419-838-11	COIL DEGAUSSING	
64	1-419-129-21	COIL, LANDING CORRECTION	
65	4-071-175-01	HOLDER, DGC	
66	4-365-808-01	SCREW (5), TAPPING	
67	4-041-021-02	HOLDER, DEGAUSE COIL	
68	* 8-933-480-00	US BOARD, COMPLETE	
69	X-4038-567-1	BASE ASSY, STAND	70
70	* 4-061-996-01	CUSHION	
71	8-610-158-71	SENSOR, MAGNETIC MIU-221D	
72	8-734-020-06	ITC ASSY	56, 59, 60
73	X-4038-568-1	PANEL ASSY, CONTROL	52
74	4-062-670-01	SPACER, PICTURE TUBE	
75	4-308-870-00	CLIP, LEAD WIRE	
76	1-452-032-00	MAGNET, DISC; 10mm φ	
77	1-452-094-00	MAGNET, ROTATABLE DISC; 15mm φ	
78	4-051-736-21	PIECE A (90), CONV. CORRECT	

5-3. PACKING MATERIALS

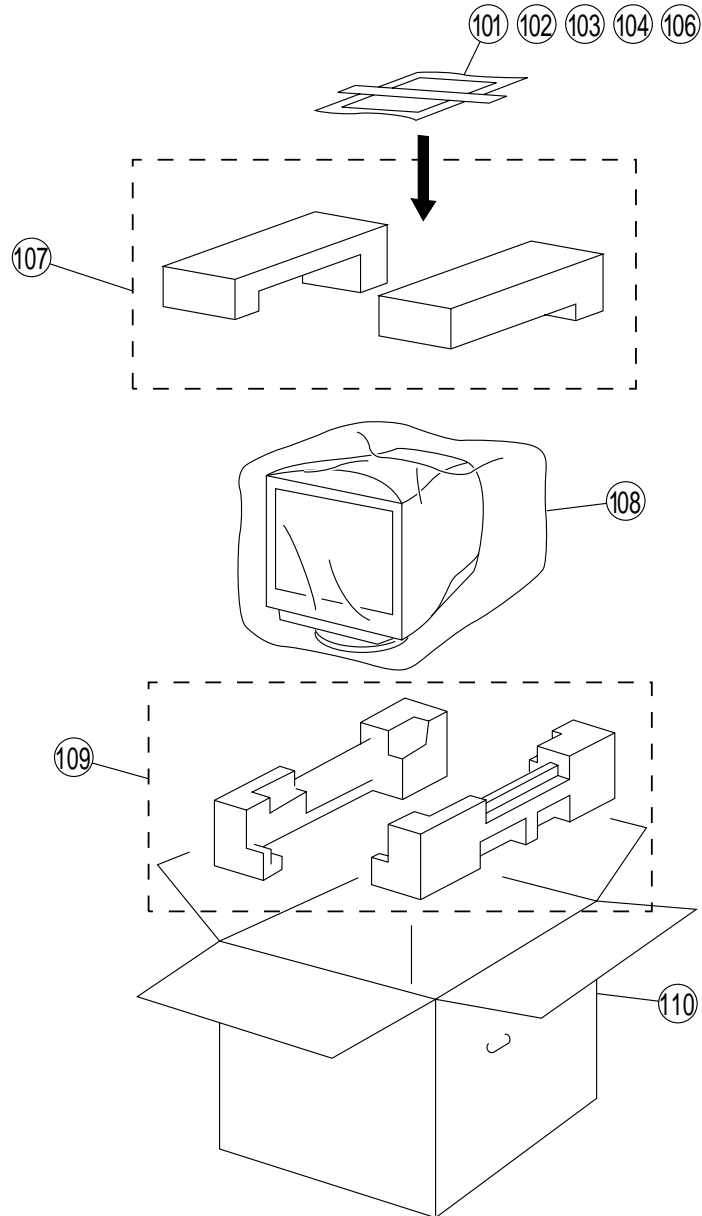

REF.NO.	PART NO.	DESCRIPTION	REMARK
101	△ 1-782-783-21	CORD SET, POWER [U/C]	
101	△ 1-782-784-31	CORD SET, POWER [AEP]	
102	1-785-512-31	CONNECTOR, D SUB (15P CHANGER)	
103	1-790-081-21	CABLE, USB	
104	4-082-083-21	MANUAL, INSTRUCTION [U/C]	
104	4-082-083-11	MANUAL, INSTRUCTION [AEP]	
106	1-757-496-31	CABLE ASSY (15P SUB X2 CONNECTOR)	
107	* 4-078-755-01	CUSHION (UPPER) (ASSY) [U/C]	
107	* 4-079-037-01	CUSHION (UPPER) (ASSY) [AEP]	
108	* 4-030-594-11	BAG, PROTECTION	
109	* 4-078-756-01	CUSHION (LOWER) (ASSY) [U/C]	
109	* 4-079-038-01	CUSHION (LOWER) (ASSY) [AEP]	
110	* 4-078-754-01	INDIVIDUAL CARTON [U/C]	
110	* 4-082-000-01	INDIVIDUAL CARTON [AEP]	

SECTION 6

ELECTRICAL PARTS LIST

NOTE:

The components identified \triangle marked are critical for safety.
Replace only with the part number specified.

Les composants identifiés par la marque \triangle sont critiques pour la sécurité.
Ne les remplacer que par une pièce portant le numéro spécifié.

When indicating parts by reference number, please include the board name.

The components identified by \boxtimes in this manual have been carefully factory-selected for each set in order to satisfy regulations regarding X-ray radiation. Should replacement be required, replace only with the value originally used.

- All variable and adjustable resistors have characteristic curve B, unless otherwise noted.

- Items marked " * " are not stocked since they are seldom required for routine service. Some delay should be anticipated when ordering these items.

RESISTORS

- All resistors are in ohms
- F : nonflammable

REF.NO.	PART NO.	DESCRIPTION	REMARK	REF.NO.	PART NO.	DESCRIPTION	REMARK
		A2 BOARD, COMPLETE *****		C032	1-164-004-11	CERAMIC (CHIP) 0.1μF 10%	25V
				C034	1-164-489-11	CERAMIC (CHIP) 0.22μF 10%	16V
	4-382-854-11	SCREW (3X10), P, SW (+) (IC002)		C035	1-104-574-11	CERAMIC 0.0047μF10%	2KV
	<CAPACITOR>			C036	1-163-251-11	CERAMIC (CHIP) 100pF 5%	50V
C001	1-162-318-11	CERAMIC 0.001μF 10%	500V	C037	1-164-004-11	CERAMIC (CHIP) 0.1μF 10%	25V
C004	1-109-982-11	CERAMIC (CHIP) 1μF 10%	10V	C038	1-163-017-00	CERAMIC (CHIP) 0.0047μF10%	50V
C007	1-164-489-11	CERAMIC (CHIP) 0.22μF 10%	16V	C039	1-115-339-11	CERAMIC (CHIP) 0.1μF 10%	50V
C009	1-104-664-11	ELECT 47μF 20%	10V	C040	1-104-664-11	ELECT 47μF 20%	10V
C010	1-107-649-11	ELECT 2.2μF 20%	250V	C044	1-162-318-11	CERAMIC 1000pF 10%	500V
C011	1-163-021-91	CERAMIC (CHIP) 0.01μF 10%	50V	C045	1-163-021-91	CERAMIC (CHIP) 0.01μF 10%	50V
C012	1-115-340-11	CERAMIC (CHIP) 0.22μF 10%	25V	C046	1-163-021-91	CERAMIC (CHIP) 0.01μF 10%	50V
C013	1-163-021-91	CERAMIC (CHIP) 0.01μF 10%	50V	C051	1-115-339-11	CERAMIC (CHIP) 0.1μF 10%	50V
C014	1-128-560-11	ELECT 22μF 20%	100V	C055	1-163-235-11	CERAMIC (CHIP) 22pF 5%	50V
C015	1-115-871-11	ELECT 1μF 20%	50V	C058	1-163-222-11	CERAMIC (CHIP) 5pF 0.25pF	50V
C016	1-128-528-11	ELECT 470μF 20%	16V	C059	1-163-021-91	CERAMIC (CHIP) 0.01μF 10%	50V
C017	1-164-489-11	CERAMIC (CHIP) 0.22μF 10%	16V	C060	1-163-021-91	CERAMIC (CHIP) 0.01μF 10%	50V
C018	1-107-888-11	ELECT 47μF 20%	25V	C061	1-163-259-91	CERAMIC (CHIP) 220pF 5%	50V
C020	1-164-489-11	CERAMIC (CHIP) 0.22μF 10%	16V	C062	1-164-489-11	CERAMIC (CHIP) 0.22μF 10%	16V
C021	1-163-021-91	CERAMIC (CHIP) 0.01μF 10%	50V	C064	1-104-665-11	ELECT 100μF 20%	10V
C023	1-104-664-11	ELECT 47μF 20%	10V	C065	1-107-882-91	ELECT 100μF 20%	16V
C025	1-164-489-11	CERAMIC (CHIP) 0.22μF 10%	16V	C068	1-163-235-11	CERAMIC (CHIP) 22pF 5%	50V
C026	1-163-227-11	CERAMIC (CHIP) 10pF 0.50PF	50V	C069	1-126-513-11	ELECT 47μF 20%	6.3V
C028	1-107-888-11	ELECT 47μF 20%	25V	C070	1-164-004-11	CERAMIC (CHIP) 0.1μF 20%	50V
C029	1-164-489-11	CERAMIC (CHIP) 0.22μF 10%	16V	C090	1-163-021-91	CERAMIC (CHIP) 0.01μF 10%	50V
C030	1-164-489-11	CERAMIC (CHIP) 0.22μF 10%	16V	C091	1-115-871-11	ELECT 1μF 20%	50V
C031	1-162-318-11	CERAMIC 0.001μF 10%	500V	C092	1-164-489-11	CERAMIC (CHIP) 0.22μF 10%	16V
				C100	1-163-021-91	CERAMIC (CHIP) 0.01μF 10%	50V
				C101	1-163-021-91	CERAMIC (CHIP) 0.01μF 10%	50V
				C102	1-163-021-91	CERAMIC (CHIP) 0.01μF 10%	50V

REF.NO.	PART NO.	DESCRIPTION	REMARK	REF.NO.	PART NO.	DESCRIPTION	REMARK
C103	1-163-257-11	CERAMIC (CHIP) 180pF 5%	50V	C302	1-163-021-91	CERAMIC (CHIP) 0.01μF 10%	50V
C104	1-163-227-11	CERAMIC (CHIP) 10pF 0.5pF	50V	C303	1-163-257-11	CERAMIC (CHIP) 180pF 5%	50V
C105	1-163-021-91	CERAMIC (CHIP) 0.01μF 10%	50V	C304	1-163-227-11	CERAMIC (CHIP) 10pF 0.5pF	50V
C106	1-136-189-00	MYLAR 0.1μF 10%	250V	C305	1-163-021-91	CERAMIC (CHIP) 0.01μF 10%	50V
C108	1-164-489-11	CERAMIC (CHIP) 0.22μF 10%	16V	C306	1-136-189-00	MYLAR 0.1μF 10%	250V
C109	1-163-235-11	CERAMIC (CHIP) 22pF 5%	50V	C308	1-164-489-11	CERAMIC (CHIP) 0.22μF 10%	16V
C110	1-163-275-11	CERAMIC (CHIP) 1000pF 5%	50V	C309	1-163-233-11	CERAMIC (CHIP) 18pF 5%	50V
C120	1-104-664-11	ELECT 47μF 20%	25V	C310	1-163-275-11	CERAMIC (CHIP) 1000pF 5%	50V
C121	1-136-189-00	MYLAR 0.1μF 10%	250V	C320	1-104-664-11	ELECT 47μF 20%	25V
C130	1-164-004-11	CERAMIC (CHIP) 0.1μF 10%	25V	C321	1-136-189-00	MYLAR 0.1μF 10%	250V
C151	1-163-021-91	CERAMIC (CHIP) 0.01μF 10%	50V	C330	1-164-004-11	CERAMIC (CHIP) 0.1μF 10%	25V
C152	1-104-664-11	ELECT 47μF 20%	25V	C351	1-163-021-91	CERAMIC (CHIP) 0.01μF 10%	50V
C200	1-163-021-91	CERAMIC (CHIP) 0.01μF 10%	50V	C352	1-104-664-11	ELECT 47μF 20%	25V
C201	1-163-021-91	CERAMIC (CHIP) 0.01μF 10%	50V			<CONNECTOR>	
C202	1-163-021-91	CERAMIC (CHIP) 0.01μF 10%	50V				
C203	1-163-257-11	CERAMIC (CHIP) 180pF 5%	50V	CN303	1-695-915-11	TAB (CONTACT)	
C204	1-163-227-11	CERAMIC (CHIP) 10pF 0.5pF	50V	CN315 *	1-778-682-11	PIN, CONNECTOR (PC BOARD) 8P	
C205	1-163-021-91	CERAMIC (CHIP) 0.01μF 10%	50V	CN318	1-764-101-11	PIN, CONNECTOR (PC BOARD) 2P	
C206	1-136-189-00	MYLAR 0.1μF 10%	250V			<DIODE>	
C208	1-164-489-11	CERAMIC (CHIP) 0.22μF 10%	16V	D002	8-719-109-89	ZENER DIODE RD5.6ESB2	
C209	1-163-235-11	CERAMIC (CHIP) 22pF 5%	50V	D004	8-719-062-51	DIODE 1PS226-115	
C210	1-163-275-11	CERAMIC (CHIP) 1000pF 5%	50V	D006	8-719-801-78	DIODE 1SS184	
C220	1-104-664-11	ELECT 47μF 20%	25V	D009	8-719-109-89	ZENER DIODE RD5.6ESB2	
C221	1-136-189-00	MYLAR 0.1μF 10%	250V	D010	8-719-109-89	ZENER DIODE RD5.6ESB2	
C230	1-164-004-11	CERAMIC (CHIP) 0.1μF 10%	25V	D011	8-719-109-89	ZENER DIODE RD5.6ESB2	
C251	1-163-021-91	CERAMIC (CHIP) 0.01μF 10%	50V	D012	8-719-062-51	DIODE 1PS226-115	
C252	1-104-664-11	ELECT 47μF 20%	25V	D016	8-719-109-89	ZENER DIODE RD5.6ESB2	
C300	1-163-021-91	CERAMIC (CHIP) 0.01μF 10%	50V				
C301	1-163-021-91	CERAMIC (CHIP) 0.01μF 10%	50V				

REF.NO.	PART NO.	DESCRIPTION	REMARK	REF.NO.	PART NO.	DESCRIPTION	REMARK
D018	8-719-911-19	DIODE 1SS119-25		FB007	1-414-231-22	INDUCTOR	
D019	8-719-062-51	DIODE 1PS226-115		FB008	1-216-295-11	SHORT	0
D020	8-719-911-19	DIODE 1SS119-25		FB009	1-414-231-22	INDUCTOR	
D101	8-719-062-51	DIODE 1PS226-115					
D104	8-719-052-12	DIODE 1SS376TE-17			<IC>		
D105	8-719-052-12	DIODE 1SS376TE-17		IC001	8-759-680-73	IC M61312SP	
D106	8-719-052-12	DIODE 1SS376TE-17		IC002	8-749-015-91	IC FA4301	
D108	8-719-066-10	DIODE 1PS181-115		IC003	8-759-681-38	IC CXD9548M	
D111	8-719-062-51	DIODE 1PS226-115		IC004	8-759-502-82	IC LM324M	
D201	8-719-062-51	DIODE 1PS226-115		IC005	8-759-058-60	IC TC7SU04FU(TE85R)	
D204	8-719-052-12	DIODE 1SS376TE-17		IC006	8-759-584-98	IC SN74AHCT04NSR	
D205	8-719-052-12	DIODE 1SS376TE-17		IC007	8-759-697-54	IC BR24C21F-E2	
D206	8-719-052-12	DIODE 1SS376TE-17		IC008	8-759-680-75	IC M61323SP	
D208	8-719-066-10	DIODE 1PS181-115		IC011	8-759-592-79	IC BA00AST-V5	
D211	8-719-062-51	DIODE 1PS226-115					
D301	8-719-062-51	DIODE 1PS226-115			<JACK>		
D304	8-719-052-12	DIODE 1SS376TE-17		J001	△ 1-451-524-11	SOCKET, PICTURE TUBE	
D305	8-719-052-12	DIODE 1SS376TE-17					
D306	8-719-052-12	DIODE 1SS376TE-17			<COIL>		
D308	8-719-066-10	DIODE 1PS181-115		L001	1-412-537-31	INDUCTOR	100μH
D311	8-719-062-51	DIODE 1PS226-115		L002	1-414-940-21	INDUCTOR	100μH
		<FERRITE BEAD>		L003	1-412-537-31	INDUCTOR	100μH
FB001	1-412-911-11	FERRITE	1.1μH	L004	1-412-529-11	INDUCTOR	22μH
FB002	1-412-911-11	FERRITE	1.1μH	L005	1-412-537-31	INDUCTOR	100μH
FB003	1-412-911-11	FERRITE	1.1μH				
FB004	1-412-911-11	FERRITE	1.1μH	L006	1-412-537-31	INDUCTOR	100μH
FB005	1-412-911-11	FERRITE	1.1μH	L007	1-414-940-21	INDUCTOR	100μH
				L101	1-412-478-11	INDUCTOR	0.15μH

REF.NO.	PART NO.	DESCRIPTION	REMARK	REF.NO.	PART NO.	DESCRIPTION	REMARK
L102	1-412-478-11	INDUCTOR	0.15μH	R011	1-216-057-00	RES-CHIP	2.2K 5% 1/10W
L103	1-412-478-11	INDUCTOR	0.15μH	R012	1-216-057-00	RES-CHIP	2.2K 5% 1/10W
L201	1-412-478-11	INDUCTOR	0.15μH	R013	1-216-025-11	RES-CHIP	100 5% 1/10W
L202	1-412-478-11	INDUCTOR	0.15μH	R014	1-216-025-11	RES-CHIP	100 5% 1/10W
L203	1-412-478-11	INDUCTOR	0.15μH	R015	1-216-057-00	RES-CHIP	2.2K 5% 1/10W
L301	1-412-478-11	INDUCTOR	0.15μH	R016	1-216-057-00	RES-CHIP	2.2K 5% 1/10W
L302	1-412-478-11	INDUCTOR	0.15μH	R017	1-216-041-00	RES-CHIP	470 5% 1/10W
L303	1-412-478-11	INDUCTOR	0.15μH	R018	1-216-009-91	RES-CHIP	100 5% 1/10W
				R019	1-216-025-11	RES-CHIP	100 5% 1/10W
				R020	1-216-025-11	RES-CHIP	100 5% 1/10W
	<TRANSISTOR>			R021	1-216-025-11	RES-CHIP	100 5% 1/10W
Q101	8-729-120-28	TRANSISTOR 2SC1623-L5L6		R024	1-216-065-91	RES-CHIP	4.7K 5% 1/10W
Q105	8-729-041-66	TRANSISTOR 2SC4015TV2		R025	1-216-065-91	RES-CHIP	4.7K 5% 1/10W
Q106	8-729-200-17	TRANSISTOR 2SA1091-0		R026	1-216-017-91	RES-CHIP	47 5% 1/10W
Q201	8-729-120-28	TRANSISTOR 2SC1623-L5L6		R029	1-216-017-91	RES-CHIP	47 5% 1/10W
Q205	8-729-041-66	TRANSISTOR 2SC4015TV2		R031	1-216-089-11	RES-CHIP	47K 5% 1/10W
Q206	8-729-200-17	TRANSISTOR 2SA1091-0		R032	1-216-049-11	RES-CHIP	1K 5% 1/10W
Q301	8-729-120-28	TRANSISTOR 2SC1623-L5L6		R033	1-216-045-00	RES-CHIP	680 5% 1/10W
Q305	8-729-041-66	TRANSISTOR 2SC4015TV2		R034	1-216-041-00	RES-CHIP	470 5% 1/10W
Q306	8-729-200-17	TRANSISTOR 2SA1091-0		R037	1-216-295-11	SHORT	0
				R038	1-216-017-91	RES-CHIP	47 5% 1/10W
				R039	1-216-017-91	RES-CHIP	47 5% 1/10W
				R040	1-216-065-91	RES-CHIP	4.7K 5% 1/10W
				R041	1-216-065-91	RES-CHIP	4.7K 5% 1/10W
				R044	1-216-295-11	SHORT	0
	<RESISTOR>			R045	1-216-025-11	RES-CHIP	100 5% 1/10W
R003	1-216-073-00	RES-CHIP	10K 5% 1/10W	R046	1-216-077-91	RES-CHIP	15K 5% 1/10W
R006	1-216-025-11	RES-CHIP	100 5% 1/10W	R048	1-216-017-91	RES-CHIP	47 5% 1/10W
R007	1-216-025-11	RES-CHIP	100 5% 1/10W	R049	1-216-025-11	RES-CHIP	100 5% 1/10W
R008	1-216-025-11	RES-CHIP	100 5% 1/10W	R052	1-259-884-11	CARBON	4.7M 5% 1/4W
R010	1-216-025-11	RES-CHIP	100 5% 1/10W				

REF.NO.	PART NO.	DESCRIPTION			REMARK	REF.NO.	PART NO.	DESCRIPTION			REMARK
R054	1-216-057-00	RES-CHIP	2.2K	5%	1/10W	R123	1-216-047-91	RES-CHIP	820	5%	1/10W
R055	1-216-073-00	RES-CHIP	10K	5%	1/10W	R125	1-216-091-00	RES-CHIP	56K	5%	1/10W
R058	1-216-025-11	RES-CHIP	100	5%	1/10W	R129	1-216-121-11	RES-CHIP	1M	5%	1/10W
R059	1-216-057-00	RES-CHIP	2.2K	5%	1/10W	R130	1-216-013-00	RES-CHIP	33	5%	1/10W
R064	1-260-127-11	CARBON	220K	5%	1/2W	R131	1-216-057-00	RES-CHIP	2.2K	5%	1/10W
R077	1-216-077-91	RES-CHIP	15K	5%	1/10W	R132	1-216-097-11	RES-CHIP	100K	5%	1/10W
R078	1-216-668-11	METAL (CHIP)	5.1K	0.5%	1/10W	R134	1-216-113-00	RES-CHIP	470K	5%	1/10W
R079	1-216-663-11	METAL (CHIP)	3.3K	0.5%	1/10W	R135	1-216-033-00	RES-CHIP	220	5%	1/10W
R080	1-216-661-11	METAL (CHIP)	2.7K	0.5%	1/10W	R136	1-216-113-00	RES-CHIP	470K	5%	1/10W
R082	1-216-369-00	METAL OXIDE	1	5%	2W	R137	1-260-324-11	CARBON	470	5%	1/4W
R092	1-216-077-91	RES-CHIP	15K	5%	1/10W	R138	1-216-017-91	RES-CHIP	47	5%	1/10W
R095	1-216-295-11	SHORT	0			R140	1-216-013-00	RES-CHIP	33	5%	1/10W
R101	1-215-394-00	METAL	75	1%	1/4W	R141	1-216-129-00	RES-CHIP	2.2M	5%	1/10W
R103	1-216-097-11	RES-CHIP	100K	5%	1/10W	R148	1-216-017-91	RES-CHIP	47	5%	1/10W
R104	1-216-295-11	SHORT	0			R151	1-219-497-11	CARBON	22	5%	1/2W
R105	1-216-065-91	RES-CHIP	4.7K	5%	1/10W	R161	1-215-394-00	METAL	75	1%	1/4W
R106	1-216-097-11	RES-CHIP	100K	5%	1/10W	R163	1-216-017-91	RES-CHIP	47	5%	1/10W
R107	1-216-107-00	RES-CHIP	270K	5%	1/10W	R167	1-216-121-11	RES-CHIP	1M	5%	1/10W
R108	1-216-101-00	RES-CHIP	150K	5%	1/10W	R201	1-215-394-00	METAL	75	1%	1/4W
R109	1-216-121-11	RES-CHIP	1M	5%	1/10W	R203	1-216-097-11	RES-CHIP	100K	5%	1/10W
R110	1-216-053-00	RES-CHIP	1.5K	5%	1/10W	R204	1-216-295-11	SHORT	0		
R111	1-216-049-11	RES-CHIP	1K	5%	1/10W	R205	1-216-065-91	RES-CHIP	4.7K	5%	1/10W
R112	1-216-013-00	RES-CHIP	33	5%	1/10W	R206	1-216-097-11	RES-CHIP	100K	5%	1/10W
R114	1-216-009-91	RES-CHIP	22	5%	1/10W	R207	1-216-107-00	RES-CHIP	270K	5%	1/10W
R115	1-216-081-00	RES-CHIP	22K	5%	1/10W	R208	1-216-101-00	RES-CHIP	150K	5%	1/10W
R116	1-216-065-91	RES-CHIP	4.7K	5%	1/10W	R209	1-216-121-11	RES-CHIP	1M	5%	1/10W
R117	1-216-017-91	RES-CHIP	47	5%	1/10W	R210	1-216-053-00	RES-CHIP	1.5K	5%	1/10W
R121	1-216-113-00	RES-CHIP	470K	5%	1/10W	R211	1-216-049-11	RES-CHIP	1K	5%	1/10W
R122	1-216-121-11	RES-CHIP	1M	5%	1/10W	R212	1-216-013-00	RES-CHIP	33	5%	1/10W

REF.NO.	PART NO.	DESCRIPTION			REMARK	REF.NO.	PART NO.	DESCRIPTION			REMARK
R214	1-216-009-91	RES-CHIP	22	5%	1/10W	R307	1-216-107-00	RES-CHIP	270K	5%	1/10W
R215	1-216-081-00	RES-CHIP	22K	5%	1/10W	R308	1-216-101-00	RES-CHIP	150K	5%	1/10W
R216	1-216-065-91	RES-CHIP	4.7K	5%	1/10W	R309	1-216-121-11	RES-CHIP	1M	5%	1/10W
R217	1-216-017-91	RES-CHIP	47	5%	1/10W	R310	1-216-053-00	RES-CHIP	1.5K	5%	1/10W
R221	1-216-113-00	RES-CHIP	470K	5%	1/10W	R311	1-216-049-11	CARBON	56	5%	1/4W
R222	1-216-121-11	RES-CHIP	1M	5%	1/10W	R312	1-216-013-00	RES-CHIP	33	5%	1/10W
R223	1-216-047-91	RES-CHIP	820	5%	1/10W	R314	1-216-009-91	RES-CHIP	22	5%	1/10W
R225	1-216-091-00	RES-CHIP	56K	5%	1/10W	R315	1-216-081-00	RES-CHIP	22K	5%	1/10W
R229	1-216-121-00	RES-CHIP	1M	5%	1/10W	R316	1-216-065-91	RES-CHIP	4.7K	5%	1/10W
R230	1-216-013-00	RES-CHIP	33	5%	1/10W	R317	1-216-017-91	RES-CHIP	47	5%	1/10W
R231	1-216-057-00	RES-CHIP	2.2K	5%	1/10W	R321	1-216-113-00	RES-CHIP	470K	5%	1/10W
R232	1-216-097-11	RES-CHIP	100K	5%	1/10W	R322	1-216-121-11	RES-CHIP	1M	5%	1/10W
R234	1-216-113-00	RES-CHIP	470K	5%	1/10W	R323	1-216-047-91	RES-CHIP	820	5%	1/10W
R235	1-216-033-00	RES-CHIP	220	5%	1/10W	R325	1-216-091-00	RES-CHIP	56K	5%	1/10W
R236	1-216-113-00	RES-CHIP	470K	5%	1/10W	R329	1-216-121-11	RES-CHIP	1M	5%	1/10W
R237	1-260-324-11	CARBON	470	5%	1/4W	R330	1-216-013-00	RES-CHIP	33	5%	1/10W
R238	1-216-017-91	RES-CHIP	47	5%	1/10W	R331	1-216-057-00	RES-CHIP	2.2K	5%	1/10W
R240	1-216-013-00	RES-CHIP	33	5%	1/10W	R332	1-216-097-11	RES-CHIP	100K	5%	1/10W
R241	1-216-129-00	RES-CHIP	2.2M	5%	1/10W	R334	1-216-113-00	RES-CHIP	470K	5%	1/10W
R248	1-216-017-91	RES-CHIP	47	5%	1/10W	R335	1-216-033-00	RES-CHIP	220	5%	1/10W
R251	1-219-497-11	CARBON	22	5%	1/2W	R336	1-216-113-00	RES-CHIP	470K	5%	1/10W
R261	1-215-394-00	METAL	75	1%	1/4W	R337	1-260-324-11	CARBON	470	5%	1/4W
R263	1-216-017-91	RES-CHIP	47	5%	1/10W	R338	1-216-017-91	RES-CHIP	47	5%	1/10W
R267	1-216-121-00	RES-CHIP	1M	5%	1/10W	R340	1-216-013-00	RES-CHIP	33	5%	1/10W
R301	1-215-394-00	METAL	75	1%	1/4W	R341	1-216-129-00	RES-CHIP	2.2M	5%	1/10W
R303	1-216-097-11	RES-CHIP	100K	5%	1/10W	R348	1-216-017-91	RES-CHIP	47	5%	1/10W
R304	1-216-295-11	SHORT	0			R351	1-219-497-11	CARBON	22	5%	1/2W
R305	1-216-065-91	RES-CHIP	4.7K	5%	1/10W	R361	1-215-394-00	METAL	75	1%	1/4W
R306	1-216-097-11	RES-CHIP	100K	5%	1/10W	R363	1-216-017-91	RES-CHIP	47	5%	1/10W

REF.NO.	PART NO.	DESCRIPTION	REMARK
R367	1-216-121-11	RES-CHIP	1M 5% 1/10W
<SPARK GAP>			
SG001	1-519-422-11	SPARK GAP	
SG002	1-576-354-21	SPARK GAP	
SG101	1-576-354-21	SPARK GAP	
SG201	1-576-354-21	SPARK GAP	
SG301	1-576-354-21	SPARK GAP	
<CRYSTAL>			
X001	1-760-682-21	VIBRATOR, CRYSTAL (24.5 MHz)	



REF.NO.	PART NO.	DESCRIPTION	REMARK	REF.NO.	PART NO.	DESCRIPTION	REMARK	
C545	1-117-663-11	FILM	0.22 μ F 5%	250V	C635	1-163-005-11	CERAMIC (CHIP) 470pF 10% 50V	
C546	1-163-021-91	CERAMIC (CHIP)	0.01 μ F 10%	50V	C636	1-164-161-11	CERAMIC (CHIP) 0.0022 μ F 10% 50V	
C547	1-107-846-11	FILM	0.1 μ F 5%	250V	C640	1-126-964-11	ELECT 10 μ F 20% 50V	
C548	1-163-021-91	CERAMIC (CHIP)	0.01 μ F 10%	50V	C641	1-107-792-11	CERAMIC 100pF 5% 1KV	
C549	1-136-060-00	FILM	0.047 μ F 5%	400V	C642	1-136-189-00	MYLAR 0.1 μ F 10% 250V	
C550	1-163-021-91	CERAMIC (CHIP)	0.01 μ F 10%	50V	C643	1-107-792-11	CERAMIC 100pF 5% 1KV	
C554	1-163-009-11	CERAMIC (CHIP)	0.001 μ F 10%	50V	C644	1-136-165-00	FILM 0.1 μ F 5% 50V	
C559	1-163-038-11	CERAMIC (CHIP)	0.1 μ F	25V	C645	1-136-479-11	FILM 0.001 μ F 2% 50V	
C560	1-137-856-11	FILM	0.018 μ F 5%	400V	C646	1-126-961-11	ELECT 2.2 μ F 20% 50V	
C561	1-163-021-91	CERAMIC (CHIP)	0.01 μ F 10%	50V	C647	1-126-963-11	ELECT 4.7 μ F 20% 50V	
C562	1-163-009-11	CERAMIC (CHIP)	0.001 μ F 10%	50V	C648	1-126-967-11	ELECT 47 μ F 20% 50V	
C563	1-104-572-11	CERAMIC	0.0022 μ F 10%	2KV	C649	1-163-009-11	CERAMIC (CHIP) 0.001 μ F 10% 50V	
C564	1-163-021-91	CERAMIC (CHIP)	0.01 μ F 10%	50V	C650	1-107-656-11	ELECT 100 μ F 20% 250V	
C565	1-164-004-11	CERAMIC (CHIP)	0.1 μ F 10%	25V	C652	1-128-563-11	ELECT 100 μ F 20% 100V	
C601	△ 1-107-533-51	MYLAR	1 μ F 20%	250V	C654	1-126-943-11	ELECT 2200 μ F 20% 25V	
C602	△ 1-104-708-51	MYLAR	0.47 μ F 20%	250V	C655	1-104-664-11	ELECT 47 μ F 20% 25V	
C603	△ 1-113-900-51	CERAMIC	470pF 10%	250V	C656	1-126-943-11	ELECT 2200 μ F 20% 25V	
C604	△ 1-113-900-51	CERAMIC	470pF 10%	250V	C657	1-104-664-11	ELECT 47 μ F 20% 25V	
C605	△ 1-113-926-91	CERAMIC	0.0047 μ F	250V	C658	1-137-725-21	FILM 8200pF 3% 800V	
C606	△ 1-113-926-91	CERAMIC	0.0047 μ F	250V	C667	1-107-909-11	ELECT 47 μ F 20% 16V	
C607	1-119-913-51	CERAMIC	2200pF 20%	250V	C680	1-115-747-51	ELECT 0.0068F 20% 10V	
C610	1-137-673-11	ELECT	330 μ F 20%	450V	C681	1-107-889-11	ELECT 220 μ F 20% 10V	
C611	1-117-227-11	MYLAR	1 μ F 10%	450V	C682	1-137-368-11	MYLAR 0.0047 μ F 5% 50V	
C612	1-136-169-00	FILM	0.22 μ F 5%	50V	C683	1-115-706-11	ELECT 220 μ F 20% 6.3V	
C613	1-126-967-11	ELECT	47 μ F 20%	50V	C686	1-115-706-11	ELECT 220 μ F 20% 6.3V	
C614	1-163-251-11	CERAMIC (CHIP)	100pF 5%	50V	C687	1-130-495-00	MYLAR 0.1 μ F 5% 50V	
C629	1-163-017-00	CERAMIC (CHIP)	0.0047 μ F 10%	50V	C692	1-115-706-11	ELECT 220 μ F 20% 6.3V	
C630	1-163-038-11	CERAMIC (CHIP)	0.1 μ F	25V	C701	1-163-003-11	CERAMIC (CHIP) 330pF 10% 50V	
C631	1-104-665-11	ELECT	100 μ F 20%	25V	C703	1-163-003-11	CERAMIC (CHIP) 330pF 10% 50V	
C632	1-126-961-11	ELECT	2.2 μ F 20%	50V				



REF.NO.	PART NO.	DESCRIPTION	REMARK	REF.NO.	PART NO.	DESCRIPTION	REMARK
C704	1-137-150-11	MYLAR	0.01μF 5% 50V	C904	1-115-339-11	CERAMIC (CHIP) 0.1μF 10% 50V	50V
C705	1-164-004-11	CERAMIC (CHIP)	0.1μF 10% 25V	C905	1-163-133-00	CERAMIC (CHIP) 470pF 5% 50V	50V
C706	1-137-150-11	MYLAR	0.01μF 5% 50V	C906	1-163-251-11	CERAMIC (CHIP) 100pF 5% 50V	50V
C707	1-104-666-11	ELECT	220μF 20% 25V	C908	1-163-021-91	CERAMIC (CHIP) 0.01μF 10% 50V	50V
C708	1-104-666-11	ELECT	220μF 20% 25V	C909	1-104-665-11	ELECT 100μF 20% 25V	25V
C711	1-163-239-11	CERAMIC (CHIP)	33pF 5% 50V	C910	1-163-259-91	CERAMIC (CHIP) 220pF 5% 50V	50V
C712	1-163-239-11	CERAMIC (CHIP)	33pF 5% 50V	C911	1-163-137-00	CERAMIC (CHIP) 680pF 5% 50V	50V
C713	1-163-021-91	CERAMIC (CHIP)	0.01μF 10% 50V	C913	1-135-842-51	ELECT 47μF 20% 250V	250V
C714	1-163-021-91	CERAMIC (CHIP)	0.01μF 10% 50V	C915	1-137-867-11	FILM 470pF 5% 250V	250V
C718	1-163-038-11	CERAMIC (CHIP)	0.1μF 25V	C916	1-117-665-11	FILM 0.33μF 5% 250V	250V
C719	1-163-038-11	CERAMIC (CHIP)	0.1μF 25V	C917	1-115-339-11	CERAMIC (CHIP) 0.1μF 10% 50V	50V
C720	1-163-021-91	CERAMIC (CHIP)	0.01μF 10% 50V	C918	1-117-626-11	FILM 2000pF 3% 1.2KV	1.2KV
C721	1-128-562-11	ELECT	47μF 20% 100V	C919	1-115-349-51	CERAMIC 0.01μF 2KV	2KV
C723	1-128-560-11	ELECT	22μF 20% 100V	C920	1-115-349-51	CERAMIC 0.01μF 2KV	2KV
C724	1-162-134-11	CERAMIC	470pF 10% 2KV	C921	1-163-038-11	CERAMIC (CHIP) 0.1μF 25V	25V
C726	1-163-038-11	CERAMIC (CHIP)	0.1μF 25V	C923	1-126-959-11	ELECT 0.47μF 20% 50V	50V
C727	1-163-038-11	CERAMIC (CHIP)	0.1μF 25V	C925	1-137-372-11	MYLAR 0.022μF 5% 50V	50V
C730	1-163-009-11	CERAMIC (CHIP)	0.001μF 10% 50V	C926	1-106-220-00	MYLAR 0.1μF 10% 100V	100V
C732	1-163-021-91	CERAMIC (CHIP)	0.01μF 10% 50V	C927	1-102-228-00	CERAMIC 470pF 10% 500V	500V
C733	1-117-722-11	ELECT	2200μF 20% 10V	C929	1-126-963-11	ELECT 4.7μF 20% 50V	50V
C734	1-164-004-11	CERAMIC (CHIP)	0.1μF 10% 25V	C930	1-136-169-00	FILM 0.22μF 5% 50V	50V
C736	1-126-967-11	ELECT	47μF 20% 50V	C932	1-164-004-11	CERAMIC (CHIP) 0.1μF 10% 25V	25V
C737	1-126-967-11	ELECT	47μF 20% 50V	C933	1-104-664-11	ELECT 47μF 20% 25V	25V
C738	1-136-169-00	FILM	0.22μF 5% 50V	C935	1-163-021-91	CERAMIC (CHIP) 0.01μF 10% 50V	50V
C761	1-163-021-91	CERAMIC (CHIP)	0.01μF 10% 50V	C936	1-163-009-11	CERAMIC (CHIP) 0.001μF 10% 50V	50V
C900	1-107-713-11	ELECT	4.7μF 20% 50V	C937	1-128-551-11	ELECT 22μF 20% 25V	25V
C901	1-104-665-11	ELECT	100μF 20% 25V	C938	1-126-935-11	ELECT 470μF 20% 16V	16V
C902	1-163-021-91	CERAMIC (CHIP)	0.01μF 10% 50V	C939	1-136-205-11	MYLAR 0.022μF 10% 400V	400V
C903	1-126-962-11	ELECT	3.3μF 20% 50V				



REF.NO.	PART NO.	DESCRIPTION	REMARK	REF.NO.	PART NO.	DESCRIPTION	REMARK
		<CONNECTOR>					
CN501	* 1-793-239-11	PIN, CONNECTOR (PC BOARD) 6P		D519	8-719-069-54	ZENER DIODE UDZS-TE17-5.1B	
CN601	* 1-580-689-11	PIN, CONNECTOR (PC BOARD) 4P		D520	8-719-911-19	DIODE 1SS119-25	
CN602	* 1-691-960-11	PIN, CONNECTOR (PC BOARD) 3P		D521	8-719-911-19	DIODE 1SS119-25	
CN604	1-770-724-11	CONNECTOR, BOARD TO BOARD 9P		D610	△ 8-719-510-53	DIODE D4SB60L	
CN605	* 1-564-507-11	PLUG, CONNECTOR 4P		D613	8-719-304-63	DIODE RM11C	
CN701	* 1-764-333-11	PLUG, CONNECTOR 10P		D631	8-719-063-73	DIODE D1NL20U-TR	
CN904	1-695-915-11	TAB (CONTACT)		D632	8-719-059-23	DIODE P6KE200AG23	
CN1101*	1-508-879-11	BASE POST		D633	8-719-069-63	DIODE ERB38-06V1	
CN1102	1-774-628-11	CONNECTOR, BOARD TO BOARD 17P		D634	8-719-063-73	DIODE D1NL20U-TR	
CN1103*	1-564-511-11	PLUG, CONNECTOR 8P		D635	8-719-110-67	ZENER DIODE RD27ES-B2	
		<DIODE>		D641	8-719-069-63	DIODE ERB38-06V1	
D401	8-719-018-84	DIODE D2S6M		D643	8-719-073-01	DIODE MA111-(K8).S0	
D405	8-719-109-85	ZENER DIODE RD5.1ESB2		D644	8-719-073-01	DIODE MA111-(K8).S0	
D406	8-719-050-84	DIODE RB441Q-40T-77		D650	8-719-064-49	DIODE D4SBL40	
D501	8-719-110-47	ZENER DIODE RD18ESB		D651	8-719-063-74	DIODE D1NL20U-TR2	
D502	8-719-054-71	DIODE D5SC4M-F		D652	8-719-052-91	DIODE D4SBS4-F	
D503	8-719-110-47	ZENER DIODE RD18ESB		D680	8-719-510-41	DIODE D10SC9M	
D504	8-719-081-76	DIODE 5VUZ52 (SONY)		D690	8-719-911-19	DIODE 1SS119-25	
D505	8-719-052-86	DIODE D2L40-TA		D692	8-719-911-19	DIODE 1SS119-25	
D506	8-719-062-89	ZENER DIODE HZS5B2-TE		D694	8-719-911-19	DIODE 1SS119-25	
D509	8-719-073-01	DIODE MA111-(K8).S0		D697	8-719-073-01	DIODE MA111-(K8).S0	
D510	8-719-082-50	DIODE 11DF2N-TA2B2		D701	8-719-911-19	DIODE 1SS119-25	
D512	8-719-911-19	DIODE 1SS119-25		D702	8-719-911-19	DIODE 1SS119-25	
D516	8-719-052-90	DIODE D1NL40-TA		D703	8-719-911-19	DIODE 1SS119-25	
D517	8-719-082-50	DIODE 11DF2N-TA2B2		D705	8-719-073-01	DIODE MA111-(K8).S0	
D518	8-719-050-84	DIODE RB441Q-40T-77		D706	8-719-069-54	ZENER DIODE UDZS-TE17-5.1B	
				D901	8-719-073-01	DIODE MA111-(K8).S0	
				D906	8-719-977-40	ZENER DIODE DTZ13B	
				D907	8-719-052-86	DIODE D2L40-TA	



REF.NO.	PART NO.	DESCRIPTION	REMARK	REF.NO.	PART NO.	DESCRIPTION	REMARK
D909	8-719-110-47	ZENER DIODE RD18ESB				<FUSE HOLDER>	
D910	8-719-028-72	DIODE RGP02-17EL-6433		FH601	1-533-223-11	HOLDER, FUSE (F601)	
D911	8-719-018-82	DIODE RGP02-20EL-6394		FH602	1-533-223-11	HOLDER, FUSE (F601)	
D912	8-719-110-42	ZENER DIODE RD15ES-B3					
D914	8-719-970-83	DIODE HSS82-TJ				<IC>	
D917	8-719-069-60	ZENER DIODE UDZS-TE17-9.1B					
D918	8-719-073-01	DIODE MA111-(K8).S0		IC401	8-759-192-71	IC STV9379	
D919	8-719-069-54	ZENER DIODE UDZS-TE17-5.1B		IC501	8-759-585-82	IC BA9759F-E2	
D920	8-719-977-28	ZENER DIODE DTZ10B		IC610	8-749-018-08	IC MZ1532	
D921	8-719-911-19	DIODE 1SS119-25		IC620	8-759-670-30	IC MCZ3001D	
D922	8-719-073-01	DIODE MA111-(K8).S0		IC630	8-759-535-32	IC FA13842P	
D923	8-719-073-01	DIODE MA111-(K8).S0		IC640	8-749-018-07	IC SEB3-LF4	
		<FUSE>		IC652	8-759-669-10	IC BA3953T-V5	
#1	F601	△ 1-576-233-11	H.B.C. FUSE (6.3A/250V)	IC654	8-759-701-79	IC NJM7812FA	
		<FERRITE BEAD>		IC680	8-759-682-42	IC MM1431ATT	
FB501	1-410-397-21	FERRITE	1.1μH	IC701	8-759-822-38	IC LA6510	
FB555	1-216-295-11	SHORT	0	IC702	8-749-017-48	IC STK391-220	
FB901	1-412-911-11	FERRITE	1.1μH	IC703	8-759-803-42	IC LA6500-FA	
FB902	1-414-231-22	INDUCTOR		IC901	8-759-585-81	IC BA9758FS-E2	
FB1000	1-414-231-22	INDUCTOR		IC902	8-759-701-01	IC NJM2904M	
FB1002	1-216-295-11	SHORT	0			<CHIP CONDUCTOR>	
FB1005	1-216-295-11	SHORT	0	JR001	1-216-295-11	SHORT	0
FB1007	1-216-295-11	SHORT	0	JR002	1-216-296-11	SHORT	0
				JR003	1-216-296-11	SHORT	0
				JR004	1-216-296-11	SHORT	0
				JR006	1-216-296-11	SHORT	0
				JR007	1-216-295-11	SHORT	0



REF.NO.	PART NO.	DESCRIPTION	REMARK	REF.NO.	PART NO.	DESCRIPTION	REMARK
Q521	8-729-901-00	TRANSISTOR DTC124EK				<RESISTOR>	
Q523	8-729-027-31	TRANSISTOR DTA124EKA-T146					
Q524	8-729-901-00	TRANSISTOR DTC124EK		R401	1-249-383-11	CARBON 1.5 5%	1/4W
Q525	8-729-027-31	TRANSISTOR DTA124EKA-T146		R402	1-215-867-00	METAL OXIDE 470 5%	1W
Q526	8-729-027-31	TRANSISTOR DTA124EKA-T146		R403	1-214-796-00	METAL 1.5 1%	1/2W
Q527	8-729-027-31	TRANSISTOR DTA124EKA-T146		R404	1-215-449-00	METAL 15K 1%	1/4W
Q528	8-729-901-00	TRANSISTOR DTC124EK		R405	1-214-796-00	METAL 1.5 1%	1/2W
Q529	8-729-901-00	TRANSISTOR DTC124EK		R406	1-215-451-00	METAL 18K 1%	1/4W
Q530	8-729-901-00	TRANSISTOR DTC124EK		R407	1-216-675-91	METAL (CHIP) 10K 0.5%	1/10W
Q610	8-729-029-55	TRANSISTOR DTA143ZSA-TP		R408	1-216-097-11	RES-CHIP 100K 5%	1/10W
Q611	8-729-029-96	TRANSISTOR DTC143XSA		R409	1-216-679-11	METAL (CHIP) 15K 0.5%	1/10W
Q630	8-729-045-03	TRANSISTOR 2SK2647-01MR-F91		R410	1-216-681-11	METAL (CHIP) 18K 0.5%	1/10W
Q640	8-729-052-29	TRANSISTOR 2SK2876-01MR-F122		R501	1-216-049-11	RES-CHIP 1K 5%	1/10W
Q641	8-729-052-29	TRANSISTOR 2SK2876-01MR-F122		R502	1-216-025-11	RES-CHIP 100 5%	1/10W
Q652	8-729-029-66	TRANSISTOR DTC114ESA		R503	1-216-033-00	RES-CHIP 220 5%	1/10W
Q701	8-729-800-32	TRANSISTOR 2SC2362K-G		R504	1-216-073-00	RES-CHIP 10K 5%	1/10W
Q702	8-729-025-68	TRANSISTOR 2SC2362KF-AA		R505	1-216-081-00	RES-CHIP 22K 5%	1/10W
Q703	8-729-820-50	TRANSISTOR 2SA1016KFG-AA		R506	1-249-393-11	CARBON 10 5%	1/4W
Q704	8-729-207-82	TRANSISTOR 2SC3421-Y		R507	1-249-433-11	CARBON 22K 5%	1/4W
Q705	8-729-207-89	TRANSISTOR 2SA1358-Y		R508	1-215-861-00	METAL OXIDE 47 5%	1W
Q706	8-729-045-47	TRANSISTOR 2SC4620TV2Q		R509	1-249-381-11	CARBON 1 5%	1/4W
Q707	8-729-026-49	TRANSISTOR 2SA1037AK-T146-R		R510	1-219-726-11	METAL 2.2 5%	10W
Q901	8-729-048-53	TRANSISTOR 2SJ569LS-CB11		R511	1-216-683-11	METAL (CHIP) 22K 0.5%	1/10W
Q902	8-729-053-42	TRANSISTOR FS5KM-18A-AT		R512	1-216-057-00	RES-CHIP 2.2K 5%	1/10W
Q903	8-729-049-86	TRANSISTOR 2PD602AR-115		R513	1-216-423-11	METAL OXIDE 27 5%	1W
Q904	8-729-049-85	TRANSISTOR 2PB710AR-115		R514	1-249-397-11	CARBON 22 5%	1/4W
Q905	8-729-046-80	TRANSISTOR 2SC4634LS-CB11		R515	1-249-425-11	CARBON 4.7K 5%	1/4W
Q906	8-729-026-49	TRANSISTOR 2SA1037AK-T146-R		R516	1-216-065-91	RES-CHIP 4.7K 5%	1/10W
Q907	8-729-216-22	TRANSISTOR 2SA1162-G		R517	1-216-089-11	RES-CHIP 47K 5%	1/10W



REF.NO.	PART NO.	DESCRIPTION			REMARK	REF.NO.	PART NO.	DESCRIPTION			REMARK
R518	1-216-033-00	RES-CHIP	220	5%	1/10W	R553	1-249-437-11	CARBON	47K	5%	1/4W
R519	1-216-037-00	RES-CHIP	330	5%	1/10W	R555	1-249-437-11	CARBON	47K	5%	1/4W
R520	1-216-033-00	RES-CHIP	220	5%	1/10W	R557	1-249-437-11	CARBON	47K	5%	1/4W
R521	1-247-807-31	CARBON	100	5%	1/4W	R559	1-249-437-11	CARBON	47K	5%	1/4W
R522	1-216-049-11	RES-CHIP	1K	5%	1/10W	R561	1-249-437-11	CARBON	47K	5%	1/4W
R523	1-216-685-11	METAL (CHIP)	27K	0.5%	1/10W	R563	1-216-065-91	RES-CHIP	4.7K	5%	1/10W
R524	1-216-663-11	METAL (CHIP)	3.3K	0.5%	1/10W	R564	1-216-065-91	RES-CHIP	4.7K	5%	1/10W
R525	1-216-657-11	METAL (CHIP)	1.8K	0.5%	1/10W	R565	1-216-065-91	RES-CHIP	4.7K	5%	1/10W
R526	1-216-689-11	METAL (CHIP)	39K	0.5%	1/10W	R566	1-216-025-11	RES-CHIP	100	5%	1/10W
R527	1-216-685-11	METAL (CHIP)	27K	0.5%	1/10W	R567	1-216-025-11	RES-CHIP	100	5%	1/10W
R528	1-215-453-00	METAL	22K	1%	1/4W	R568	1-216-025-11	RES-CHIP	100	5%	1/10W
R530	1-216-662-11	METAL (CHIP)	3K	0.5%	1/10W	R570	1-214-842-11	METAL	120	1%	1/2W
R531	1-216-661-11	METAL (CHIP)	2.7K	0.5%	1/10W	R571	1-214-842-11	METAL	120	1%	1/2W
R532	1-216-081-00	RES-CHIP	22K	5%	1/10W	R572	1-216-025-11	RES-CHIP	100	5%	1/10W
R533	1-216-681-11	METAL (CHIP)	18K	0.5%	1/10W	R573	1-216-069-00	RES-CHIP	6.8K	5%	1/10W
R534	1-216-057-00	RES-CHIP	2.2K	5%	1/10W	R574	1-216-049-11	RES-CHIP	1K	5%	1/10W
R536	1-215-863-11	METAL OXIDE	100	5%	1W	R575	1-216-041-00	RES-CHIP	470	5%	1/10W
R537	1-216-663-11	METAL (CHIP)	3.3K	0.5%	1/10W	R576	1-216-069-00	RES-CHIP	6.8K	5%	1/10W
R539	1-216-073-00	RES-CHIP	10K	5%	1/10W	R578	1-216-049-11	RES-CHIP	1K	5%	1/10W
R541	1-216-089-11	RES-CHIP	47K	5%	1/10W	R579	1-216-049-11	RES-CHIP	1K	5%	1/10W
R542	1-214-842-11	METAL	120	1%	1/2W	R580	1-249-413-11	CARBON	470	5%	1/4W
R543	1-216-081-00	RES-CHIP	22K	5%	1/10W	R581	1-249-437-11	CARBON	47K	5%	1/4W
R544	1-216-041-00	RES-CHIP	470	5%	1/10W	R583	1-216-025-11	RES-CHIP	100	5%	1/10W
R546	1-215-890-11	METAL OXIDE	470	5%	2W	R584	1-215-909-11	METAL OXIDE	47	5%	3W
R547	1-215-373-31	METAL	10	1%	1/4W	R585	1-216-381-11	METAL OXIDE	0.22	5%	3W
R548	1-260-316-51	CARBON	100	5%	1/2W	R586	1-215-909-11	METAL OXIDE	47	5%	3W
R549	1-260-312-11	CARBON	47	5%	1/2W	R588	1-216-065-91	RES-CHIP	4.7K	5%	1/10W
R550	1-247-903-00	CARBON	1M	5%	1/4W	R589	1-216-065-91	RES-CHIP	4.7K	5%	1/10W
R552	1-249-437-11	CARBON	47K	5%	1/4W	R590	1-216-065-91	RES-CHIP	4.7K	5%	1/10W



REF.NO.	PART NO.	DESCRIPTION			REMARK	REF.NO.	PART NO.	DESCRIPTION			REMARK
R591	1-249-425-11	CARBON	4.7K	5%	1/4W	R642	1-249-393-11	CARBON	10	5%	1/4W
R592	1-249-425-11	CARBON	4.7K	5%	1/4W	R643	1-243-979-71	METAL OXIDE	0.1	5%	2W
R593	1-216-065-91	RES-CHIP	4.7K	5%	1/10W	R645	1-216-073-00	RES-CHIP	10K	5%	1/10W
R594	1-216-065-91	RES-CHIP	4.7K	5%	1/10W	R646	1-216-001-00	RES-CHIP	10	5%	1/10W
R596	1-247-807-31	CARBON	100	5%	1/4W	R647	1-219-512-11	CARBON	2.2M	5%	1/2W
R598	1-216-663-11	METAL (CHIP)	3.3K	0.5%	1/10W	R651	1-215-421-00	METAL	1K	1%	1/4W
R599	1-218-756-11	METAL (CHIP)	150K	0.5%	1/10W	R652	1-216-081-00	RES-CHIP	22K	5%	1/10W
R601	△ 1-220-825-91	CARBON	330K	5%	1/2W	R653	1-216-671-11	METAL (CHIP)	6.8K	0.5%	1/10W
R610	1-217-152-00	METAL	0.33	10%	2W	R654	1-216-017-91	RES-CHIP	47	5%	1/10W
R611	1-217-153-00	METAL	0.47	10%	2W	R655	1-216-049-11	RES-CHIP	1K	5%	1/10W
R612	1-247-807-31	CARBON	100	5%	1/4W	R656	1-216-025-11	RES-CHIP	100	5%	1/10W
R614	1-247-807-31	CARBON	100	5%	1/4W	R660	1-216-667-11	METAL (CHIP)	4.7K	0.5%	1/10W
R615	1-249-427-11	CARBON	6.8K	5%	1/4W	R661	1-216-295-11	SHORT	0		
R617	1-216-073-00	RES-CHIP	10K	5%	1/10W	R665	1-249-421-11	CARBON	2.2K	5%	1/4W
R618	1-216-049-11	RES-CHIP	1K	5%	1/10W	R670	1-216-679-11	METAL (CHIP)	15K	0.5%	1/10W
#1 R620	△ 1-202-933-61	FUSE	0.1	10%	1/2W	R671	1-216-675-91	METAL (CHIP)	10K	0.5%	1/10W
R629	1-216-671-11	METAL (CHIP)	6.8K	0.5%	1/10W	R675	1-219-512-11	CARBON	2.2M	5%	1/2W
R630	1-249-381-11	CARBON	1	5%	1/4W	R676	1-218-756-11	METAL (CHIP)	150K	0.5%	1/10W
R631	1-216-369-00	METAL OXIDE	1	5%	2W	R686	1-216-033-00	RES-CHIP	220	5%	1/10W
R632	1-216-081-00	RES-CHIP	22K	5%	1/10W	R687	1-216-081-00	RES-CHIP	22K	5%	1/10W
R633	1-249-406-11	CARBON	120	5%	1/4W	R691	1-244-160-91	METAL	36K	0.5%	1/4W
R634	1-249-417-11	CARBON	1K	5%	1/4W	R692	1-244-160-91	METAL	36K	0.5%	1/4W
R635	1-260-135-11	CARBON	1M	5%	1/2W	R693	1-244-160-91	METAL	36K	0.5%	1/4W
R636	1-260-135-11	CARBON	1M	5%	1/2W	R694	1-243-985-91	METAL	33K	0.5%	1/4W
R637	1-216-069-00	RES-CHIP	6.8K	5%	1/10W	R696	1-260-092-11	CARBON	270	5%	1/2W
R638	1-216-073-00	RES-CHIP	10K	5%	1/10W	R698	1-216-679-11	METAL (CHIP)	15K	0.5%	1/10W
R639	1-249-419-11	CARBON	1.5K	5%	1/4W	R699	1-216-647-11	METAL (CHIP)	680	0.5%	1/10W
R640	1-249-420-11	CARBON	1.8K	5%	1/4W	R700	1-216-095-00	RES-CHIP	82K	5%	1/10W
R641	1-216-073-00	RES-CHIP	10K	5%	1/10W						



REF.NO.	PART NO.	DESCRIPTION			REMARK	REF.NO.	PART NO.	DESCRIPTION			REMARK
R701	1-249-385-11	CARBON	2.2	5%	1/4W	R738	1-216-069-00	RES-CHIP	6.8K	5%	1/10W
R702	1-216-073-00	RES-CHIP	10K	5%	1/10W	R739	1-215-451-00	METAL	18K	1%	1/4W
R703	1-249-385-11	CARBON	2.2	5%	1/4W	R740	1-216-089-11	RES-CHIP	47K	5%	1/10W
R704	1-216-049-11	RES-CHIP	1K	5%	1/10W	R741	1-216-049-11	RES-CHIP	1K	5%	1/10W
R706	1-215-887-00	METAL OXIDE	150	5%	2W	R742	1-216-065-91	RES-CHIP	4.7K	5%	1/10W
R707	1-249-440-11	CARBON	82K	5%	1/4W	R743	1-216-039-00	RES-CHIP	390	5%	1/10W
R709	1-216-065-91	RES-CHIP	4.7K	5%	1/10W	R744	1-249-413-11	CARBON	470	5%	1/4W
R710	1-216-673-11	METAL (CHIP)	8.2K	0.5%	1/10W	R745	1-249-389-11	CARBON	4.7	5%	1/4W
R711	1-216-674-11	METAL (CHIP)	9.1K	0.5%	1/10W	R746	1-249-389-11	CARBON	4.7	5%	1/4W
R712	1-249-425-11	CARBON	4.7K	5%	1/4W	R747	1-215-881-11	METAL OXIDE	15	5%	2W
R713	1-215-887-00	METAL OXIDE	150	5%	2W	R748	1-219-510-11	CARBON	470K	5%	1/2W
R716	1-249-385-11	CARBON	2.2	5%	1/4W	R749	1-216-057-00	RES-CHIP	2.2K	5%	1/10W
R717	1-249-385-11	CARBON	2.2	5%	1/4W	R753	1-249-393-11	CARBON	10	5%	1/4W
R718	1-215-866-11	METAL OXIDE	330	5%	1W	R754	1-216-675-91	METAL (CHIP)	10K	0.5%	1/10W
R719	1-216-373-11	METAL OXIDE	2.2	5%	2W	R755	1-216-673-11	METAL (CHIP)	8.2K	0.5%	1/10W
R721	1-216-675-91	METAL (CHIP)	10K	0.5%	1/10W	R756	1-249-421-11	CARBON	2.2K	5%	1/4W
R722	1-215-866-11	METAL OXIDE	330	5%	1W	R757	1-216-073-00	RES-CHIP	10K	5%	1/10W
R724	1-216-675-91	METAL (CHIP)	10K	0.5%	1/10W	R758	1-249-385-11	CARBON	2.2	5%	1/4W
R725	1-216-373-11	METAL OXIDE	2.2	5%	2W	R759	1-249-385-11	CARBON	2.2	5%	1/4W
R726	1-216-673-11	METAL (CHIP)	8.2K	0.5%	1/10W	R760	1-216-093-91	RES-CHIP	68K	5%	1/10W
R727	1-216-673-11	METAL (CHIP)	8.2K	0.5%	1/10W	R761	1-215-449-00	METAL	15K	1%	1/4W
R728	1-216-675-91	METAL (CHIP)	10K	0.5%	1/10W	R901	1-216-097-11	RES-CHIP	100K	5%	1/10W
R729	1-216-673-11	METAL (CHIP)	8.2K	0.5%	1/10W	R902	1-216-089-11	RES-CHIP	47K	5%	1/10W
R731	1-216-081-00	RES-CHIP	22K	5%	1/10W	R903	1-218-758-11	METAL (CHIP)	180K	0.5%	1/10W
R732	1-249-383-11	CARBON	1.5	5%	1/4W	R904	1-216-057-00	RES-CHIP	2.2K	5%	1/10W
R733	1-215-859-00	METAL OXIDE	22	5%	1W	R905	1-216-049-11	RES-CHIP	1K	5%	1/10W
R734	1-215-865-11	METAL OXIDE	220	5%	1W	R907	1-216-065-91	RES-CHIP	4.7K	5%	1/10W
R735	1-216-667-11	METAL (CHIP)	4.7K	0.5%	1/10W	R908	1-249-425-11	CARBON	4.7K	5%	1/4W
R737	1-216-059-00	RES-CHIP	2.7K	5%	1/10W	R909	1-219-727-11	METAL	68	5%	10W



REF.NO.	PART NO.	DESCRIPTION	REMARK
SG901	1-517-499-21	SPARK GAP	
SG902	1-519-422-11	SPARK GAP	
SG903	1-519-422-11	SPARK GAP	

<TRANSFORMER>

	T501	1-435-188-11	TRANSFORMER, FERRITE (HDT)	
	T503	1-435-140-21	TRANSFORMER, FERRITE (LCT)	
	T504	1-431-413-11	TRANSFORMER, FERRITE (HST)	
#1	T601	△ 1-429-180-11	TRANSFORMER, LINE FILTER	
#1	T620	△ 1-435-748-11	TRANSFORMER, CONVERTER (PIT)	
#1	T630	△ 1-435-751-11	TRANSFORMER, CONVERTER (SRT)	
	T701	1-435-129-11	TRANSFORMER, FERRITE (DFT)	
#1	T901	△ 1-453-359-11	TRANSFORMER ASSY, FLYBACK (NX-4702/KM7E)	
	T902	1-411-567-31	INDUCTOR 500μH	

<THERMISTOR>

	TH401	1-807-925-11	THERMISTOR	
	TH601	△ 1-803-546-11	THERMISTOR (NTH22D6R0QA)	
	THP602	△ 1-809-827-11	THERMISTOR, PTC	

<VARISTOR>

	VDR601	△ 1-803-918-51	VARISTOR (TNR14V621K660)	
	VDR602	△ 1-810-622-21	VARISTOR	

REF.NO.	PART NO.	DESCRIPTION	REMARK	REF.NO.	PART NO.	DESCRIPTION	REMARK
		DA BOARD, COMPLETE *****					
		<CAPACITOR>					
C1101	1-164-004-11	CERAMIC (CHIP) 0.1μF	10% 25V	C1127	1-125-838-11	CERAMIC (CHIP) 2.2μF	10% 6.3V
C1102	1-164-004-11	CERAMIC (CHIP) 0.1μF	10% 25V	C1128	1-126-246-11	ELECT (CHIP) 220μF	20% 4V
C1103	1-164-004-11	CERAMIC (CHIP) 0.1μF	10% 25V	C1129	1-163-007-11	CERAMIC (CHIP) 680pF	10% 50V
C1104	1-164-004-11	CERAMIC (CHIP) 0.1μF	10% 25V	C1130	1-164-492-11	CERAMIC (CHIP) 0.15μF	10% 16V
C1105	1-163-021-91	CERAMIC (CHIP) 0.01μF	10% 50V	C1131	1-164-004-11	CERAMIC (CHIP) 0.1μF	10% 25V
				C1132	1-163-021-91	CERAMIC (CHIP) 0.01μF	10% 50V
C1108	1-163-021-91	CERAMIC (CHIP) 0.01μF	10% 50V				
C1109	1-163-021-91	CERAMIC (CHIP) 0.01μF	10% 50V	C1133	1-126-246-11	ELECT (CHIP) 220μF	20% 4V
C1110	1-163-021-91	CERAMIC (CHIP) 0.01μF	10% 50V	C1137	1-126-205-11	ELECT (CHIP) 47μF	20% 6.3V
C1111	1-163-021-91	CERAMIC (CHIP) 0.01μF	10% 50V	C1138	1-163-251-11	CERAMIC (CHIP) 100pF	5% 50V
C1112	1-164-004-11	CERAMIC (CHIP) 0.1μF	10% 25V	C1139	1-164-004-11	CERAMIC (CHIP) 0.1μF	10% 25V
				C1140	1-163-251-11	CERAMIC (CHIP) 100pF	5% 50V
C1113	1-163-021-91	CERAMIC (CHIP) 0.01μF	10% 50V			<DIODE>	
C1114	1-163-017-00	CERAMIC (CHIP) 0.0047μF	10% 50V	D1104	8-719-027-76	DIODE 1SS357-TPH3	
C1115	1-163-021-91	CERAMIC (CHIP) 0.01μF	10% 50V	D1105	8-719-067-40	ZENER DIODE STZ6.8N-T146	
C1116	1-163-021-91	CERAMIC (CHIP) 0.01μF	10% 50V	D1106	8-719-067-40	ZENER DIODE STZ6.8N-T146	
C1117	1-163-019-00	CERAMIC (CHIP) 0.0068μF	10% 50V	D1107	8-719-067-40	ZENER DIODE STZ6.8N-T146	
						<FERRITE BEAD>	
C1118	1-164-004-11	CERAMIC (CHIP) 0.1μF	10% 25V	FB1101	1-543-963-22	FERRITE	
C1119	1-163-021-91	CERAMIC (CHIP) 0.01μF	10% 50V				
C1120	1-163-251-11	CERAMIC (CHIP) 100pF	5% 50V			<IC>	
C1121	1-163-019-00	CERAMIC (CHIP) 0.0068μF	10% 50V	IC1101	8-759-697-78	IC CXD9563Q	
C1122	1-164-004-11	CERAMIC (CHIP) 0.1μF	10% 25V	IC1102	8-759-701-01	IC NJM2904M	
C1123	1-164-004-11	CERAMIC (CHIP) 0.1μF	10% 25V				
C1124	1-163-005-11	CERAMIC (CHIP) 470pF	10% 50V				
C1125	1-163-021-91	CERAMIC (CHIP) 0.01μF	10% 50V				
C1126	1-163-021-91	CERAMIC (CHIP) 0.01μF	10% 50V				

REF.NO.	PART NO.	DESCRIPTION	REMARK			REF.NO.	PART NO.	DESCRIPTION	REMARK		
	<RESISTOR>										
R1101	1-216-025-11	RES-CHIP	100	5%	1/10W	R1136	1-216-049-11	RES-CHIP	1K	5%	1/10W
R1102	1-216-057-00	RES-CHIP	2.2K	5%	1/10W	R1137	1-218-758-11	METAL (CHIP)	180K	0.5%	1/10W
R1103	1-216-025-11	RES-CHIP	100	5%	1/10W	R1139	1-216-691-11	METAL (CHIP)	47K	0.5%	1/10W
R1106	1-216-691-11	METAL (CHIP)	47K	0.5%	1/10W	R1141	1-216-025-11	RES-CHIP	100	5%	1/10W
R1108	1-216-067-00	RES-CHIP	5.6K	5%	1/10W	R1142	1-216-295-11	SHORT	0		
R1109	1-216-067-00	RES-CHIP	5.6K	5%	1/10W						
R1110	1-216-675-91	METAL (CHIP)	10K	0.5%	1/10W	<COMPOSITION CIRCUIT BLOCK>					
R1111	1-216-673-11	METAL (CHIP)	8.2K	0.5%	1/10W	RB1101	1-233-576-11	NETWORK, RESISTOR (CHIP) 100			
R1112	1-216-073-00	RES-CHIP	10K	5%	1/10W	RB1102	1-233-412-11	NETWORK, RESISTOR (CHIP) 1.0K (3216)			
R1113	1-216-665-11	METAL (CHIP)	3.9K	0.5%	1/10W	RB1103	1-233-412-11	NETWORK, RESISTOR (CHIP) 1.0K (3216)			
R1114	1-216-049-11	RES-CHIP	1K	5%	1/10W	RB1104	1-233-576-11	NETWORK, RESISTOR (CHIP) 100			
R1115	1-216-691-11	METAL (CHIP)	47K	0.5%	1/10W	RB1105	1-233-576-11	NETWORK, RESISTOR (CHIP) 100			
R1116	1-216-655-11	METAL (CHIP)	1.5K	0.5%	1/10W						
R1118	1-216-057-00	RES-CHIP	2.2K	5%	1/10W	RB1106	1-233-412-11	NETWORK, RESISTOR (CHIP) 1.0K (3216)			
R1119	1-216-049-11	RES-CHIP	1K	5%	1/10W						
R1122	1-216-659-11	METAL (CHIP)	2.2K	0.5%	1/10W	*****					
R1123	1-216-656-11	METAL (CHIP)	1.6K	0.5%	1/10W						
R1124	1-216-643-11	METAL (CHIP)	470	0.5%	1/10W						
R1125	1-216-659-11	METAL (CHIP)	2.2K	0.5%	1/10W						
R1126	1-216-642-11	METAL (CHIP)	430	0.5%	1/10W						
R1127	1-216-073-00	RES-CHIP	10K	5%	1/10W						
R1128	1-216-105-91	RES-CHIP	220K	5%	1/10W						
R1129	1-216-683-11	METAL (CHIP)	22K	0.5%	1/10W						
R1131	1-216-025-11	RES-CHIP	100	5%	1/10W						
R1132	1-216-025-11	RES-CHIP	100	5%	1/10W						
R1133	1-216-121-11	RES-CHIP	1M	5%	1/10W						
R1134	1-216-663-11	METAL (CHIP)	3.3K	0.5%	1/10W						
R1135	1-216-121-11	RES-CHIP	1M	5%	1/10W						



REF.NO.	PART NO.	DESCRIPTION	REMARK	REF.NO.	PART NO.	DESCRIPTION	REMARK
		H2 BOARD, COMPLETE *****		FB1403	1-412-911-31	FERRITE 1.1μH	
		<CAPACITOR>				<TRANSISTOR>	
C1400	1-126-795-11	ELECT	10μF 20% 50V	Q1400	8-729-029-66	TRANSISTOR DTC114ESA	
C1401	1-126-786-11	ELECT	47μF 20% 16V	Q1401	8-729-029-68	TRANSISTOR DTC114TSA	
C1402	1-126-786-11	ELECT	47μF 20% 16V	Q1402	8-729-029-40	TRANSISTOR DTA124ESA	
C1403	1-137-150-11	MYLAR	0.01μF 5% 50V			<RESISTOR>	
C1404	1-137-150-11	MYLAR	0.01μF 5% 50V	R1400	1-215-405-00	METAL 220 1% 1/4W	
C1405	1-126-786-11	ELECT	47μF 20% 16V	R1401	1-215-405-00	METAL 220 1% 1/4W	
C1407	1-126-786-11	ELECT	47μF 20% 16V	R1402	1-215-397-00	METAL 100 1% 1/4W	
C1498	1-130-495-00	MYLAR	0.1μF 5% 50V	R1403	1-215-397-00	METAL 100 1% 1/4W	
		<CONNECTOR>		R1404	1-215-413-00	METAL 470 1% 1/4W	
CN1400	1-564-593-11	PLUG, CONNECTOR 14P		R1405	1-249-441-11	CARBON 100K 5% 1/4W	
CN1401*	1-564-520-11	PLUG, CONNECTOR 5P		R1406	1-249-411-11	CARBON 330 5% 1/4W	
		<DIODE>		R1407	1-249-413-11	CARBON 470 5% 1/4W	
D1400	8-719-056-13	DIODE SML79423C-TP15 (POWER)		R1408	1-249-413-11	CARBON 470 5% 1/4W	
D1402	8-719-911-19	DIODE 1SS119-25		R1409	1-249-441-11	CARBON 100K 5% 1/4W	
D1403	8-719-911-19	DIODE 1SS119-25		R1419	1-249-441-11	CARBON 100K 5% 1/4W	
		<FERRITE BEAD>		R1420	1-249-429-11	CARBON 10K 5% 1/4W	
FB1401	1-412-911-31	FERRITE 1.1μH		R1421	1-215-445-00	METAL 10K 1% 1/4W	
FB1402	1-412-911-31	FERRITE 1.1μH		R1422	1-249-433-11	CARBON 22K 5% 1/4W	
				R1423	1-249-433-11	CARBON 22K 5% 1/4W	
				R1424	1-215-453-00	METAL 22K 1% 1/4W	



REF.NO.	PART NO.	DESCRIPTION	REMARK
---------	----------	-------------	--------

<SWITCH>

S1400	1-762-196-21	SWITCH, TACT (MENU)	
S1401	1-762-196-21	SWITCH, TACT (PICTURE)	
S1402	1-771-734-11	SWITCH, TACTILE (CONTROL/CONTRAST)	
S1403	1-571-427-11	SWITCH, SLIDE (INPUT1/INPUT2)	

<THERMISTOR>

TH1400	1-807-796-11	THERMISTOR	
--------	--------------	------------	--

REF.NO.	PART NO.	DESCRIPTION	REMARK	REF.NO.	PART NO.	DESCRIPTION	REMARK
		L2 BOARD, COMPLETE *****					
		<CAPACITOR>				<CONNECTOR>	
C1600	1-164-004-11	CERAMIC (CHIP) 0.1μF	10% 25V	CN1600	1-564-505-11	PLUG, CONNECTOR 2P	
C1604	1-163-003-11	CERAMIC (CHIP) 330pF	10% 50V	CN1601*	1-564-507-11	PLUG, CONNECTOR 4P	
C1605	1-163-021-91	CERAMIC (CHIP) 0.01μF	10% 50V	CN1602*	1-564-511-11	PLUG, CONNECTOR 8P	
C1606	1-163-021-91	CERAMIC (CHIP) 0.01μF	10% 50V			<FERRITE BEAD>	
C1607	1-163-003-11	CERAMIC (CHIP) 330pF	10% 50V	FB1600	1-412-911-11	FERRITE	1.1μH
C1608	1-164-004-11	CERAMIC (CHIP) 0.1μF	10% 25V	FB1601	1-412-911-11	FERRITE	1.1μH
C1611	1-163-021-91	CERAMIC (CHIP) 0.01μF	10% 50V	FB1602	1-412-911-11	FERRITE	1.1μH
C1613	1-163-021-91	CERAMIC (CHIP) 0.01μF	10% 50V	FB1603	1-412-911-11	FERRITE	1.1μH
C1614	1-163-021-91	CERAMIC (CHIP) 0.01μF	10% 50V	FB1604	1-412-911-11	FERRITE	1.1μH
C1617	1-164-004-11	CERAMIC (CHIP) 0.1μF	10% 25V			<IC>	
C1618	1-164-004-11	CERAMIC (CHIP) 0.1μF	10% 25V	IC1600	8-759-822-38	IC LA6510	
C1619	1-163-038-11	CERAMIC (CHIP) 0.1μF	25V	IC1601	8-759-822-38	IC LA6510	
C1621	1-164-004-11	CERAMIC (CHIP) 0.1μF	10% 25V	IC1602	8-759-426-18	IC MB88141PF-ER	
C1622	1-164-004-11	CERAMIC (CHIP) 0.1μF	10% 25V	IC1603	8-759-803-42	IC LA6500-FA	
C1623	1-115-339-11	CERAMIC (CHIP) 0.1μF	10% 50V	IC1604	8-759-822-38	IC LA6510	
C1627	1-115-339-11	CERAMIC (CHIP) 0.1μF	10% 50V	IC1605	8-759-711-59	IC NJM78L05UA-TE1	
C1628	1-104-664-11	ELECT 47μF	20% 25V			<RESISTOR>	
C1629	1-163-021-91	CERAMIC (CHIP) 0.01μF	10% 50V	R1600	1-216-073-00	RES-CHIP	10K 5% 1/10W
C1632	1-104-664-11	ELECT 47μF	20% 25V	R1601	1-216-308-00	RES-CHIP	4.7 5% 1/10W
C1633	1-126-791-11	ELECT 10μF	20% 16V	R1603	1-216-308-00	RES-CHIP	4.7 5% 1/10W
C1637	1-164-004-11	CERAMIC (CHIP) 0.1μF	10% 25V	R1604	1-216-073-00	RES-CHIP	10K 5% 1/10W
C1638	1-164-004-11	CERAMIC (CHIP) 0.1μF	10% 25V				
C1639	1-104-664-11	ELECT 47μF	20% 25V				
C1640	1-104-664-11	ELECT 47μF	20% 25V				

REF.NO.	PART NO.	DESCRIPTION			REMARK	REF.NO.	PART NO.	DESCRIPTION			REMARK
R1605	1-215-859-00	METAL OXIDE	22	5%	1W	R1653	1-249-382-11	CARBON	1.2	5%	1/4W
R1607	1-215-859-00	METAL OXIDE	22	5%	1W	R1654	1-216-025-11	RES-CHIP	100	5%	1/10W
R1608	1-216-071-00	RES-CHIP	8.2K	5%	1/10W	R1655	1-216-025-11	RES-CHIP	100	5%	1/10W
R1609	1-216-065-91	RES-CHIP	4.7K	5%	1/10W						
R1610	1-216-071-00	RES-CHIP	8.2K	5%	1/10W						
R1611	1-215-859-00	METAL OXIDE	22	5%	1W						
R1613	1-216-308-00	RES-CHIP	4.7	5%	1/10W						
R1617	1-216-065-91	RES-CHIP	4.7K	5%	1/10W						
R1621	1-216-308-00	RES-CHIP	4.7	5%	1/10W						
R1624	1-216-073-00	RES-CHIP	10K	5%	1/10W						
R1625	1-216-073-00	RES-CHIP	10K	5%	1/10W						
R1626	1-215-859-00	METAL OXIDE	22	5%	1W						
R1628	1-216-073-00	RES-CHIP	10K	5%	1/10W						
R1629	1-216-073-00	RES-CHIP	10K	5%	1/10W						
R1630	1-215-859-00	METAL OXIDE	22	5%	1W						
R1631	1-216-073-00	RES-CHIP	10K	5%	1/10W						
R1634	1-216-308-00	RES-CHIP	4.7	5%	1/10W						
R1635	1-216-077-91	RES-CHIP	15K	5%	1/10W						
R1636	1-215-859-00	METAL OXIDE	22	5%	1W						
R1640	1-216-065-91	RES-CHIP	4.7K	5%	1/10W						
R1641	1-216-079-00	RES-CHIP	18K	5%	1/10W						
R1643	1-216-308-00	RES-CHIP	4.7	5%	1/10W						
R1644	1-216-053-00	RES-CHIP	1.5K	5%	1/10W						
R1647	1-216-073-00	RES-CHIP	10K	5%	1/10W						
R1648	1-216-073-00	RES-CHIP	10K	5%	1/10W						
R1649	1-215-859-00	METAL OXIDE	22	5%	1W						
R1650	1-249-382-11	CARBON	1.2	5%	1/4W						
R1651	1-249-382-11	CARBON	1.2	5%	1/4W						
R1652	1-249-382-11	CARBON	1.2	5%	1/4W						



REF.NO.	PART NO.	DESCRIPTION	REMARK	REF.NO.	PART NO.	DESCRIPTION	REMARK
		N BOARD, COMPLETE *****				<DIODE>	
				D1001	8-719-073-01	DIODE MA111-(K8).S0	
		<CAPACITOR>				<FERRITE BEAD>	
C1001	1-163-021-91	CERAMIC (CHIP)0.01μF	10% 50V	FB1001	1-543-963-22	FERRITE	
C1002	1-163-021-91	CERAMIC (CHIP)0.01μF	10% 50V	FB1002	1-216-295-11	SHORT	0
C1004	1-163-021-91	CERAMIC (CHIP)0.01μF	10% 50V	FB1003	1-216-295-11	SHORT	0
C1005	1-163-021-91	CERAMIC (CHIP)0.01μF	10% 50V	FB1004	1-216-295-11	SHORT	0
C1014	1-126-205-11	ELECT (CHIP) 47μF	20% 6.3V	FB1005	1-216-295-11	SHORT	0
C1015	1-163-021-91	CERAMIC (CHIP)0.01μF	10% 50V	FB1006	1-216-295-11	SHORT	0
C1016	1-163-021-91	CERAMIC (CHIP)0.01μF	10% 50V	FB1007	1-216-295-11	SHORT	0
C1017	1-163-021-91	CERAMIC (CHIP)0.01μF	10% 50V			<IC>	
C1018	1-163-220-11	CERAMIC (CHIP)3pF	0.25pF 50V	IC1001	8-759-826-97	IC TMP91PW18F-1A22 (Z)	
C1019	1-163-235-11	CERAMIC (CHIP)22pF	5% 50V	IC1002	8-759-420-77	IC PST574CMT-T1	
C1020	1-126-206-11	ELECT (CHIP) 100μF	20% 6.3V	IC1003	8-759-641-86	IC BR24C16F-E2	
C1021	1-163-021-91	CERAMIC (CHIP)0.01μF	10% 50V			<TRANSISTOR>	
C1022	1-163-021-91	CERAMIC (CHIP)0.01μF	10% 50V	Q1001	8-729-029-06	TRANSISTOR DTC124EUA-T106	
C1023	1-163-021-91	CERAMIC (CHIP)0.01μF	10% 50V			<RESISTOR>	
C1027	1-163-021-91	CERAMIC (CHIP)0.01μF	10% 50V	R1001	1-216-125-00	RES-CHIP 1.5M	5% 1/10W
C1028	1-164-004-11	CERAMIC (CHIP)0.1μF	10% 25V	R1003	1-216-025-11	RES-CHIP 100	5% 1/10W
C1029	1-163-021-91	CERAMIC (CHIP)0.01μF	10% 50V	R1004	1-216-065-91	RES-CHIP 4.7K	5% 1/10W
C1030	1-163-021-91	CERAMIC (CHIP)0.01μF	10% 50V				
		<CONNECTOR>					
CN1003	1-564-521-11	PLUG, CONNECTOR 6P					



REF.NO.	PART NO.	DESCRIPTION	REMARK	REF.NO.	PART NO.	DESCRIPTION	REMARK
		US BOARD, COMPLETE *****		C2918	1-164-004-11	CERAMIC (CHIP) 0.1μF 10% 25V	
				C2923	1-163-021-91	CERAMIC (CHIP) 0.01μF 10% 50V	
		<CAPACITOR>				<CONNECTOR>	
C2601	1-163-021-91	CERAMIC (CHIP) 0.01μF	10% 50V	CN2601*	1-564-519-11	PLUG, CONNECTOR 4P	
C2602	1-126-964-11	ELECT 10μF	20% 50V	CN2901	1-794-989-11	CONNECTOR, USB (B)	
C2603	1-126-964-11	ELECT 10μF	20% 50V	CN2902	1-794-990-11	CONNECTOR, USB (A)	
C2604	1-126-964-11	ELECT 10μF	20% 50V	CN2903	1-794-990-11	CONNECTOR, USB (A)	
C2605	1-126-964-11	ELECT 10μF	20% 50V	CN2904	1-794-990-11	CONNECTOR, USB (A)	
C2606	1-126-934-11	ELECT 220μF	20% 10V	CN2905	1-794-990-11	CONNECTOR, USB (A)	
C2607	1-126-934-11	ELECT 220μF	20% 10V			<DIODE>	
C2608	1-126-934-11	ELECT 220μF	20% 10V	D2601	8-719-069-55	ZENER DIODE UDZS-TE17-5.6B	
C2609	1-126-934-11	ELECT 220μF	20% 10V	D2604	8-719-911-19	DIODE 1SS119-25	
C2610	1-104-664-11	ELECT 47μF	20% 25V	D2605	8-719-911-19	DIODE 1SS119-25	
C2611	1-104-664-11	ELECT 47μF	20% 25V	D2606	8-719-911-19	DIODE 1SS119-25	
C2612	1-163-021-91	CERAMIC (CHIP) 0.01μF	10% 50V	D2607	8-719-911-19	DIODE 1SS119-25	
C2901	1-164-004-11	CERAMIC (CHIP) 0.1μF	10% 25V	D2902	8-719-422-12	ZENER DIODE MA8039	
C2902	1-104-664-11	ELECT 47μF	20% 25V	D2903	8-719-422-12	ZENER DIODE MA8039	
C2904	1-163-021-91	CERAMIC (CHIP) 0.01μF	10% 50V	D2904	8-719-069-55	ZENER DIODE UDZS-TE17-5.6B	
C2905	1-164-489-11	CERAMIC (CHIP) 0.22μF	10% 16V	D2905	8-719-069-55	ZENER DIODE UDZS-TE17-5.6B	
C2906	1-164-489-11	CERAMIC (CHIP) 0.22μF	10% 16V	D2906	8-719-069-55	ZENER DIODE UDZS-TE17-5.6B	
C2908	1-164-489-11	CERAMIC (CHIP) 0.22μF	10% 16V	D2907	8-719-069-55	ZENER DIODE UDZS-TE17-5.6B	
C2909	1-163-237-11	CERAMIC (CHIP) 27pF	5% 50V	D2908	8-719-422-12	ZENER DIODE MA8039	
C2912	1-163-235-11	CERAMIC (CHIP) 22pF	5% 50V	D2909	8-719-422-12	ZENER DIODE MA8039	
C2914	1-164-489-11	CERAMIC (CHIP) 0.22μF	10% 16V	D2910	8-719-422-12	ZENER DIODE MA8039	
C2915	1-164-489-11	CERAMIC (CHIP) 0.22μF	10% 16V	D2911	8-719-422-12	ZENER DIODE MA8039	
C2916	1-164-004-11	CERAMIC (CHIP) 0.1μF	10% 25V				
C2917	1-164-004-11	CERAMIC (CHIP) 0.1μF	10% 25V				



REF.NO.	PART NO.	DESCRIPTION	REMARK	REF.NO.	PART NO.	DESCRIPTION	REMARK
D2912	8-719-422-12	ZENER DIODE MA8039				<IC>	
D2913	8-719-422-12	ZENER DIODE MA8039		IC2601	8-759-431-14	IC PQ3TZ53U	
D2914	8-719-422-12	ZENER DIODE MA8039		IC2602	8-749-018-35	IC SLA3006M(LF874)	
D2915	8-719-422-12	ZENER DIODE MA8039		IC2901	8-759-660-89	IC KC82C160SH	
				IC2902	8-759-165-87	IC PST600J-T	
		<FERRITE BEAD>				<TRANSISTOR>	
FB2601	1-412-911-31	FERRITE	1.1μH	Q2601	8-729-029-06	TRANSISTOR DTC124EUA-T106	
FB2602	1-410-397-21	FERRITE	1.1μH	Q2602	8-729-029-06	TRANSISTOR DTC124EUA-T106	
FB2901	1-412-911-31	FERRITE	1.1μH	Q2603	8-729-029-06	TRANSISTOR DTC124EUA-T106	
FB2903	1-412-911-31	FERRITE	1.1μH	Q2604	8-729-029-06	TRANSISTOR DTC124EUA-T106	
FB2904	1-412-911-31	FERRITE	1.1μH			<RESISTOR>	
FB2905	1-412-911-31	FERRITE	1.1μH	R2601	1-216-081-00	RES-CHIP	22K 5% 1/10W
FB2906	1-412-911-31	FERRITE	1.1μH	R2602	1-216-365-00	METAL OXIDE	0.47 5% 2W
FB2911	1-412-911-31	FERRITE	1.1μH	R2603	1-216-365-00	METAL OXIDE	0.47 5% 2W
FB2912	1-216-295-11	SHORT	0	R2611	1-216-049-11	RES-CHIP	1K 5% 1/10W
FB2913	1-216-295-11	SHORT	0	R2612	1-216-049-11	RES-CHIP	1K 5% 1/10W
FB2914	1-216-295-11	SHORT	0	R2613	1-216-049-11	RES-CHIP	1K 5% 1/10W
FB2915	1-216-295-11	SHORT	0	R2614	1-216-049-11	RES-CHIP	1K 5% 1/10W
FB2916	1-216-295-11	SHORT	0	R2618	1-216-073-00	RES-CHIP	10K 5% 1/10W
FB2917	1-216-295-11	SHORT	0	R2619	1-216-073-00	RES-CHIP	10K 5% 1/10W
FB2918	1-216-295-11	SHORT	0	R2620	1-216-073-00	RES-CHIP	10K 5% 1/10W
FB2919	1-216-295-11	SHORT	0	R2621	1-216-073-00	RES-CHIP	10K 5% 1/10W
FB2924	1-216-295-11	SHORT	0	R2622	1-216-033-00	RES-CHIP	220 5% 1/10W
FB2925	1-216-295-11	SHORT	0	R2623	1-216-033-00	RES-CHIP	220 5% 1/10W
FB2936	1-414-766-22	INDUCTOR		R2901	1-216-013-00	RES-CHIP	33 5% 1/10W



REF.NO.	PART NO.	DESCRIPTION			REMARK	REF.NO.	PART NO.	DESCRIPTION	REMARK
R2902	1-216-057-00	RES-CHIP	2.2K	5%	1/10W			<CRYSTAL>	
R2903	1-216-121-11	RES-CHIP	1M	5%	1/10W	X2901	1-767-925-21	VIBRATOR, CRYSTAL (12MHz)	
R2904	1-216-065-91	RES-CHIP	4.7K	5%	1/10W				
R2905	1-216-073-00	RES-CHIP	10K	5%	1/10W				
R2906	1-216-022-00	RES-CHIP	75	5%	1/10W				
R2907	1-216-039-00	RES-CHIP	390	5%	1/10W				

R2908	1-216-073-00	RES-CHIP	10K	5%	1/10W				
R2909	1-216-065-91	RES-CHIP	4.7K	5%	1/10W				
R2910	1-216-065-91	RES-CHIP	4.7K	5%	1/10W				
R2915	1-216-053-00	RES-CHIP	1.5K	5%	1/10W				
R2916	1-216-077-91	RES-CHIP	15K	5%	1/10W				
R2919	1-216-077-91	RES-CHIP	15K	5%	1/10W				
R2920	1-216-077-91	RES-CHIP	15K	5%	1/10W				
R2923	1-216-077-91	RES-CHIP	15K	5%	1/10W				
R2924	1-216-077-91	RES-CHIP	15K	5%	1/10W				
R2925	1-216-077-91	RES-CHIP	15K	5%	1/10W				
R2926	1-216-077-91	RES-CHIP	15K	5%	1/10W				
R2927	1-216-013-00	RES-CHIP	33	5%	1/10W				
R2928	1-216-013-00	RES-CHIP	33	5%	1/10W				
R2930	1-216-009-91	RES-CHIP	22	5%	1/10W				
R2931	1-216-009-91	RES-CHIP	22	5%	1/10W				
R2932	1-216-077-91	RES-CHIP	15K	5%	1/10W				
R2933	1-216-013-00	RES-CHIP	33	5%	1/10W				
R2934	1-216-013-00	RES-CHIP	33	5%	1/10W				
R2935	1-216-013-00	RES-CHIP	33	5%	1/10W				
R2941	1-216-013-00	RES-CHIP	33	5%	1/10W				
R2942	1-216-013-00	RES-CHIP	33	5%	1/10W				

